

GPIB Command Syntax
for

E1962B cdma2000 Mobile Test Application Revision B.01

1000-1807



Agilent Technologies

Contents

Diagram Conventions	7
Description	7
ABORT	9
AFGenerator	9
CALibration	10
CALL[:CELL]:APARameter	10
CALL:AWGNoise:POWER	11
CALL:BAND	11
CALL:CHANnel	11
CALL[:CELL]:CLPControl	12
CALL:CONNected[:STATe]	12
CALL[:CELL]:CONTrol:DOWNlink:FREQuency:AUTO	12
CALL:D2KTest	13
CALL:END	13
CALL[:CELL]:ESCAPE[:MODE]	13
CALL:FCHannel	14
CALL:HANDoff	14
CALL[:CELL]:MCCode	14
CALL[:CELL]:MNCcode	14
CALL:MS:REPorted<BCL,BWT,OPER:MODE,EIRP>	15
CALL:MS:REPorted:CAPability:CCHannel:DEDicated	15
CALL:MS:REPorted:CAPability:FCHannel	15
CALL:MS:REPorted:QUERy	15
CALL:MS:REPorted:SCHannel:FORWARD	16
CALL:MS:REPorted:CAPability:SCHannel:REVERSE	17
CALL:MS:REPorted:CLEar	17
CALL:MS:REPorted:ESN	17
CALL:MS:REPorted<MCC,MNC,MSIN>	18
CALL:MS:REPorted<ONUM,PREV,QPCH,CPCL>	18
CALL:MS:REPorted:<RCON:ENH,REG,SCIN,SCL>	19
CALL[:CELL]:NIDentity	19
CALL:OCNSource	19
CALL[:CELL]:OPERating	20
CALL:ORIGinate	20
CALL:PAGing	21
CALL:PILot	22
CALL[:CELL]:PNOFfset	22
CALL[:CELL]:POWer	22
CALL[:CELL]:PROTocol	23
CALL:QPCHannel	23
CALL[:CELL]:RCONfig	23
CALL:REGister	24
CALL[:CELL]:RFGenerator	24
CALL[:CELL]:RLGain	24
CALL:SCHannel	25

CALL:SETup:BAND	26
CALL:SETup:CHANnel	26
CALL:SETup:HANDoff	26
CALL:SETup:SYSTem	26
CALL[:CELL]:SIDentity	26
CALL[:CELL]:SOPTION	27
CALL:STATus	28
CALL:SYNC	32
CALL[:CELL]:SYSTem	32
CALL:TOTal:POWer	32
CALL:TRAFfic	32
CALL:TRIGger:TYPE	33
DISPlay	33
FETCh:CAPPower	33
FETCh:CPOWer	34
FETCh:DAPower	34
FETCh:CFERror	34
FETCh:FSTability	35
FETCh:WQQuality	36
INITiate	38
READ	39
RFANalyzer	40
SETup[:ALL]:CONTInuous	40
SETup:CAPPower	41
SETup:CFERror	42
SETup:CPOWer	43
SETup:DAPower	44
SETup:FSTability	45
SETup:WQQuality	46
STATus:OPERation:	47
STATus:PRESet	52
STATus:QUEStionable	52
Status Byte Register	61
Standard Event Status Register	62
SYSTem:APPLication	65
SYSTem:BEEPer	65
SYSTem:CONFIgure:INFOrmation:HARDware:VERBose?	65
SYSTem:COMMunicate	66
SYSTem:CORRection	66
SYSTem:CURRent:TA	67
SYSTem:ERRor?	67
SYSTem:MEASurement:RESet	67
SYSTem:PRESet	67
SYSTem:ROSCillator	67
SYSTem:SYNChronized	68

IEEE 488.2 Common Commands68

Diagram Conventions

Description

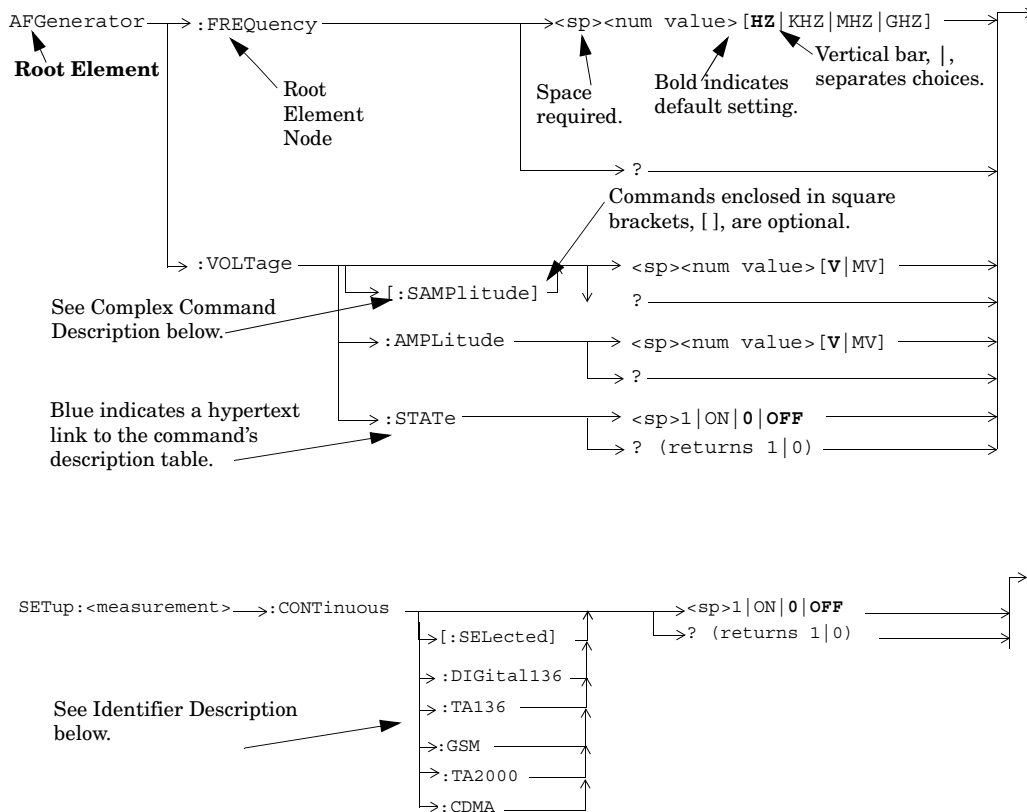

Diagram Description

Statement elements are connected by lines. Each line can be followed in only one direction, as indicated by the arrow at the end of the line. Any combination of statement elements that can be generated by starting at the **Root Element** and following the line the **direction of the arrow** is syntactically correct. The drawings show the proper use of spaces. Where spaces are required they are indicated by **<sp>**, otherwise no spaces are allowed between statement elements.

Complex Command Description

A complex command sets the state of the parameter to ON, and is used to set a value for that parameter. These parameters; amplitude, frequency, gain, number, time, and value can be used as a complex command. Refer to the specific command for the parameter that applies.

Identifier Description

Some test applications are able to test more than one radio format. There may be commands/queries that are shared by more than one radio format in the some of these test applications. Identifiers are used to specify the radio format for the command/query. The command/query is sent to the active radio format if you don't use an identifier. An identifier must be used when sending commands to the inactive radio format..

Developing Code

It is recommended that you set the Test Set's operating environment to debug. To set the Test Set debug mode to "ON" use the following syntax:

```
SYSTem:COMMunicate:GPiB:DEBUg ON
```

Units-of-Measure

Amplitude (linear)	V
Frequency	Hz
Power (logarithmic)	dBm
Time	s

ABORt

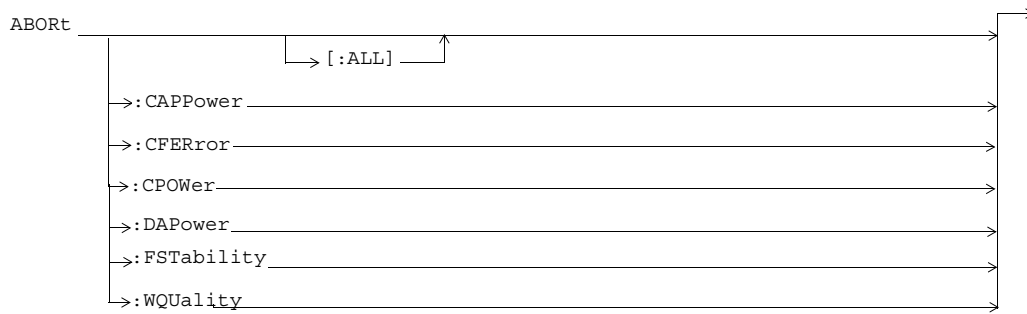

AFGenerator

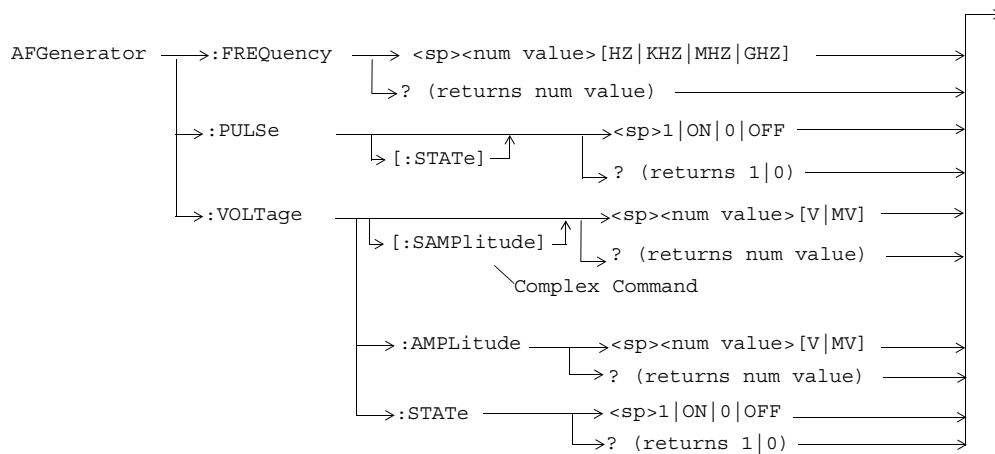

CALibration

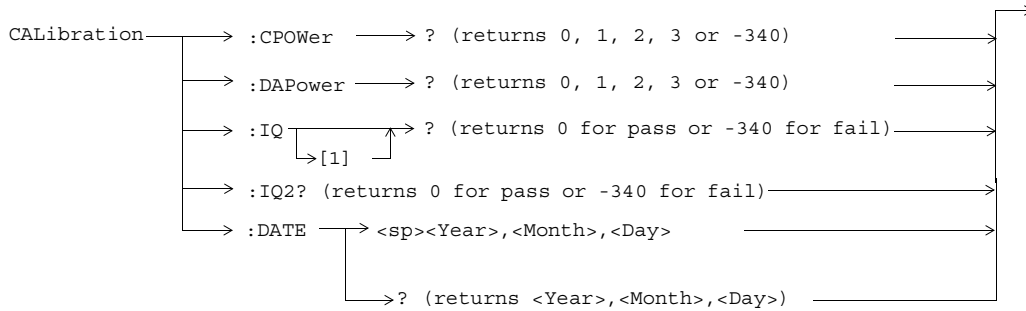

CALL[:CELL]:APARAmeter

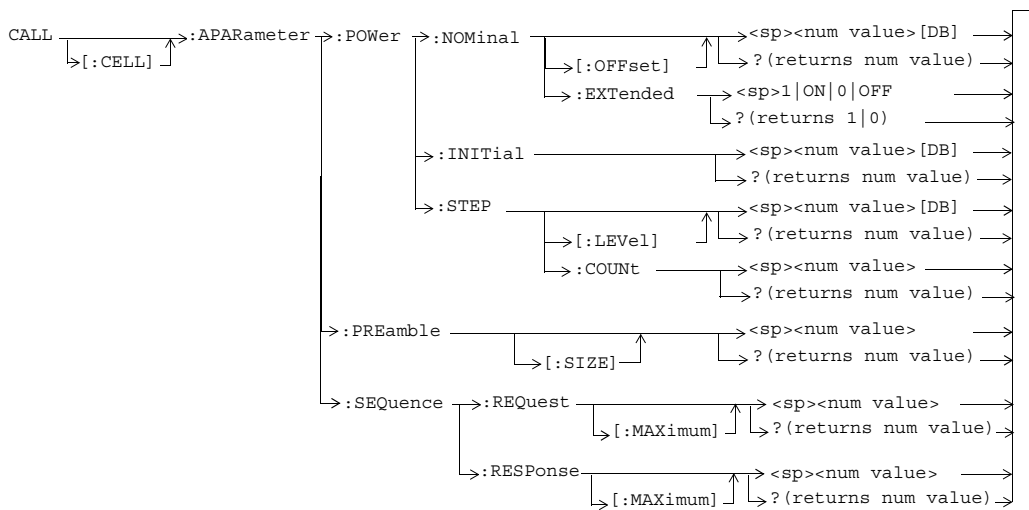

CALL:AWGNoise:POWer

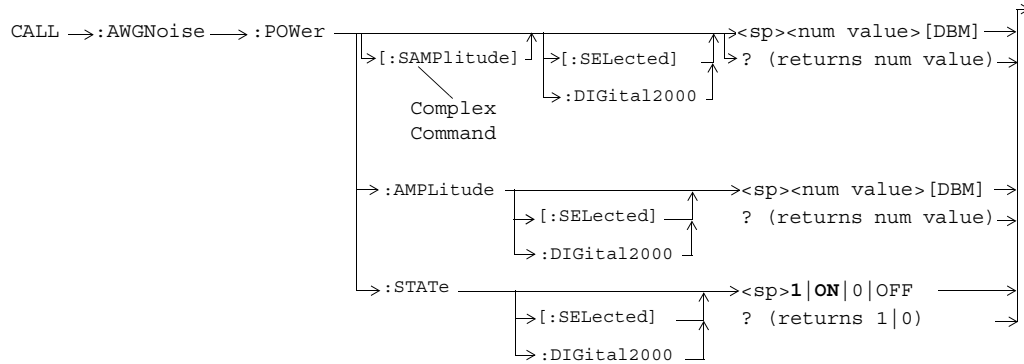

CALL:BAND

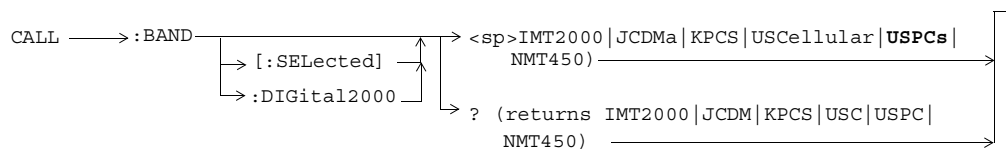

CALL:CHANnel

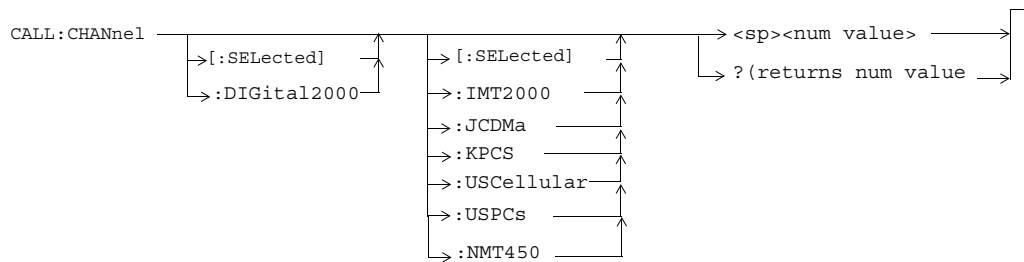

CALL[:CELL]:CLPControl

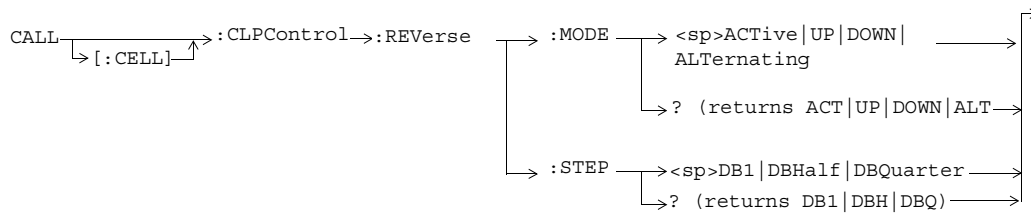

CALL:CONNECTed[:STATe]

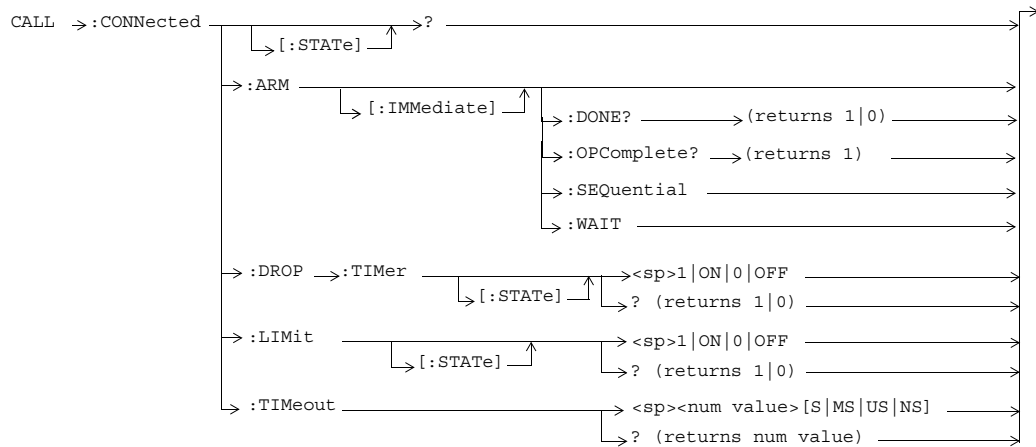

CALL[:CELL]:CONTRol:DOWNlink:FREQuency:AUTO

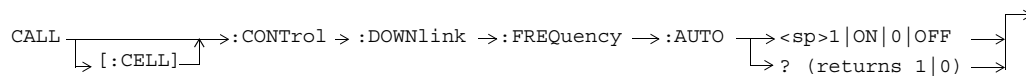

CALL:D2KTest

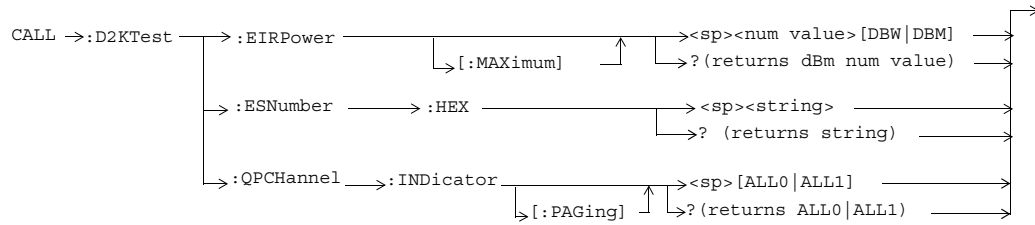

CALL:END

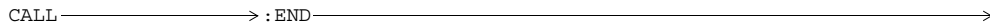

CALL[:CELL]:ESCAPE[:MODE]

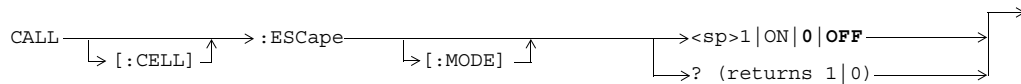

CALL:FCHannel

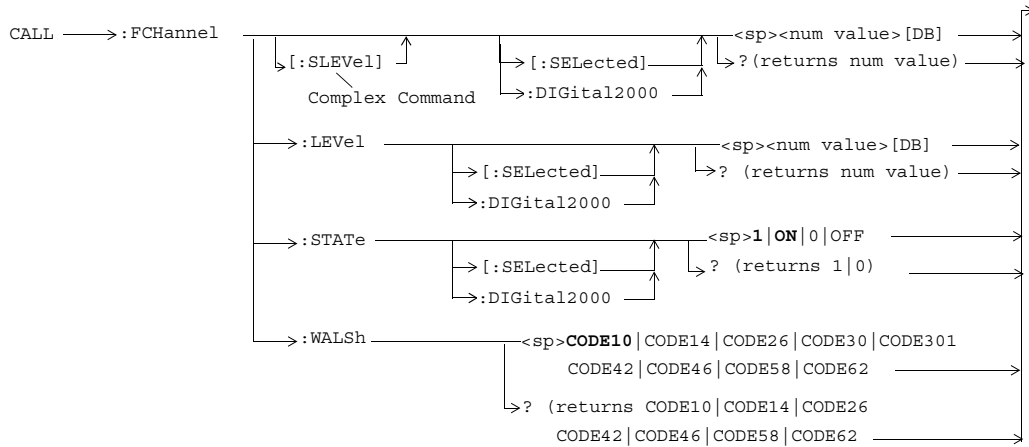

CALL:HANDoff

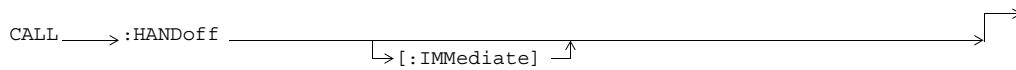

CALL[:CELL]:MCCCode

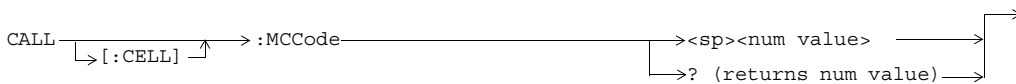

CALL[:CELL]:MNCCode

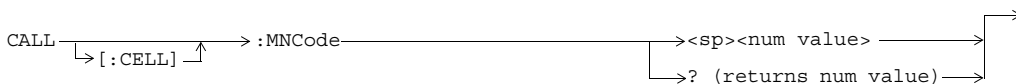

CALL:MS:REPorted<BCL,BWT,OPER:MODE,EIRP>

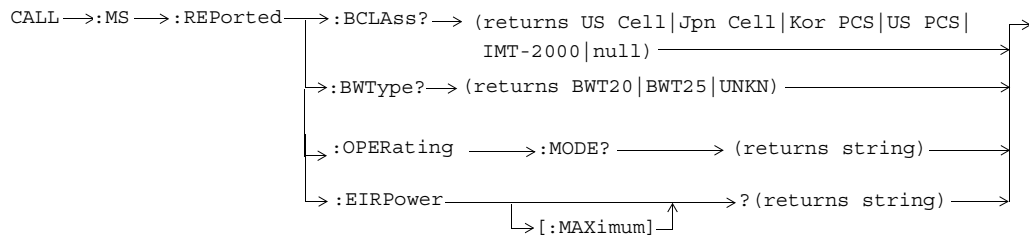

CALL:MS:REPorted:CAPability:CCHannel:DEDicated

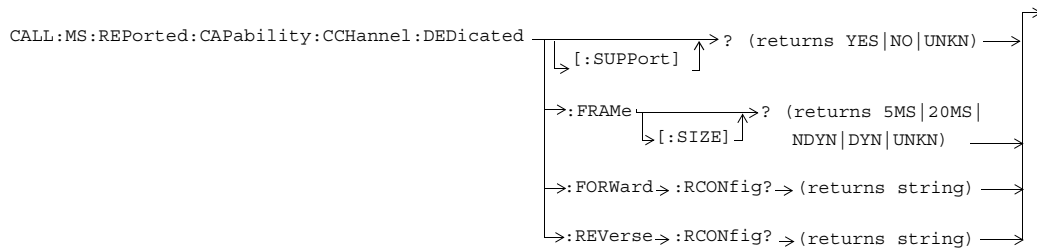

CALL:MS:REPorted:CAPability:FCHannel

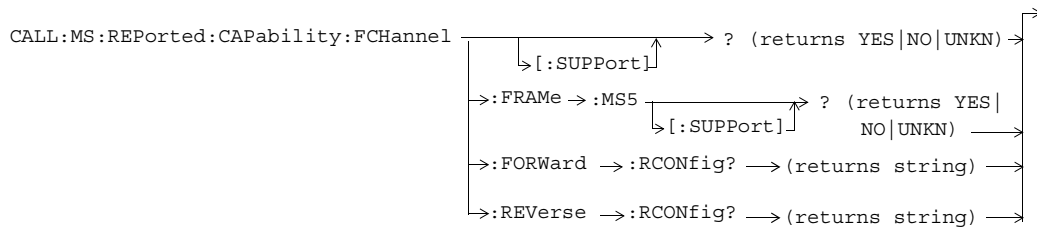

CALL:MS:REPorted:QUERy

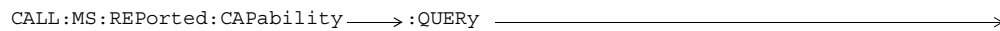

CALL:MS:REPorted:SCHannel:FORWARD

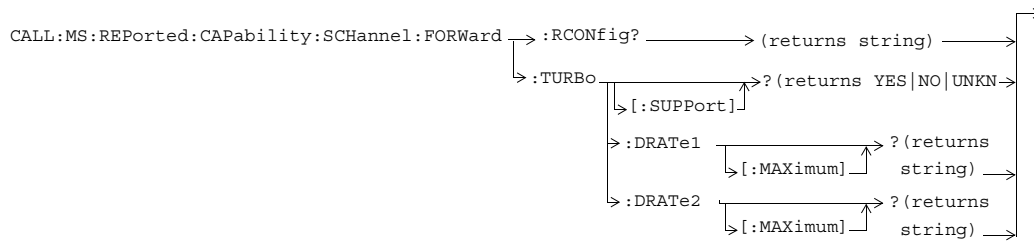
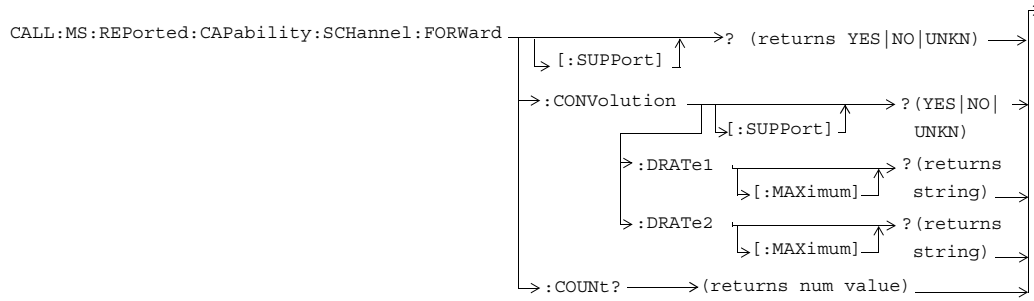

CALL:MS:REPorted:CAPability:SCHannel:REVerse

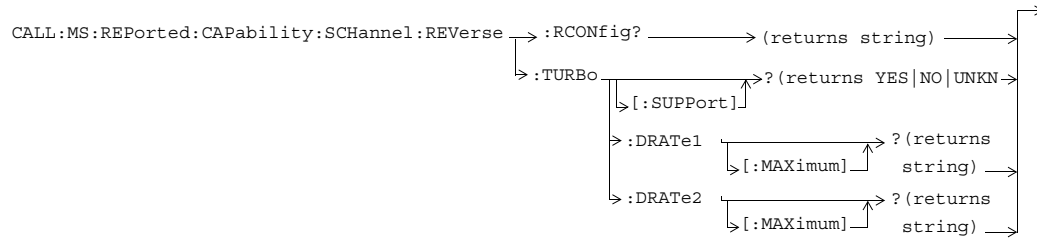
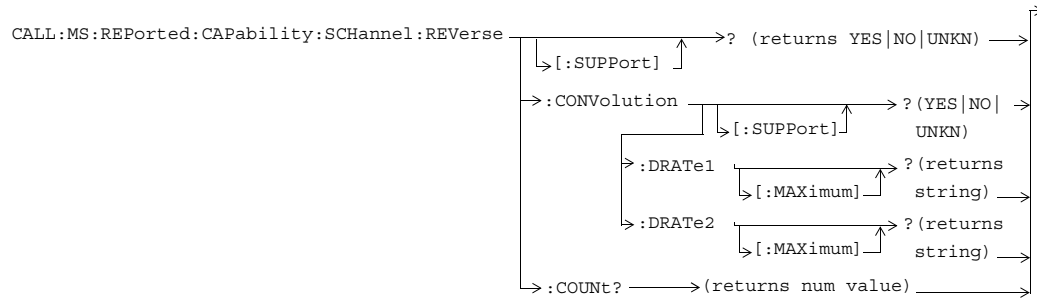

CALL:MS:REPorted:CLEar

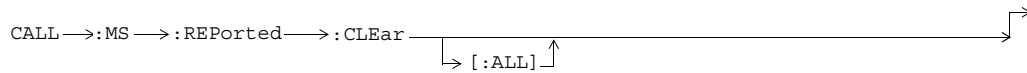

CALL:MS:REPorted:ESN

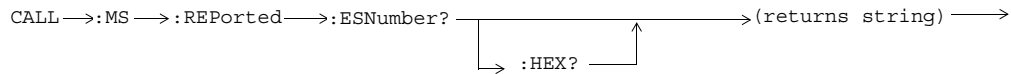

CALL:MS:REPorted<MCC,MNC,MSIN>

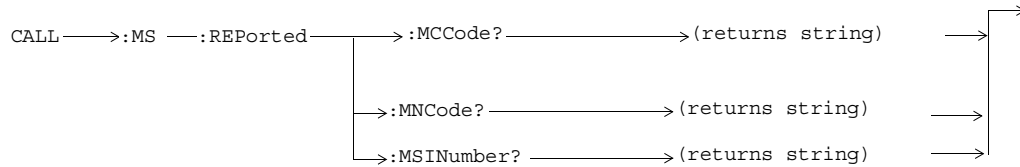

CALL:MS:REPorted<ONUM,PREV,QPCH,CPCL>

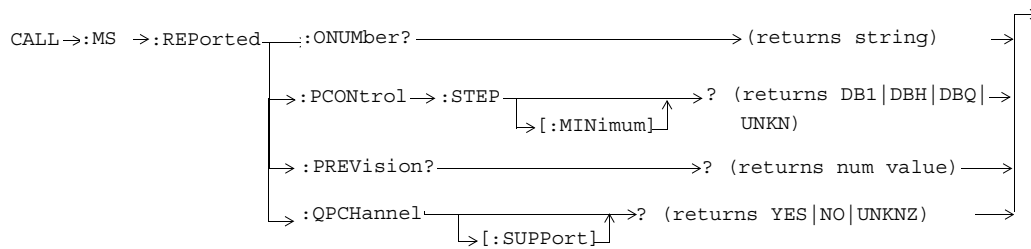

CALL:MS:REPorted:<RCON:ENH,REG,SCIN,SCL>

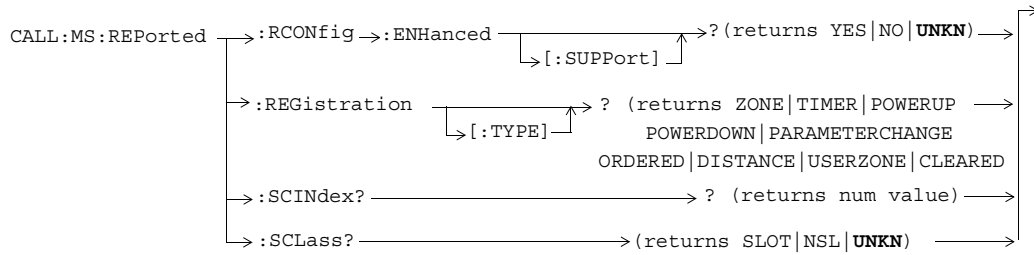

CALL[:CELL]:NIDentity



CALL:OCNSource

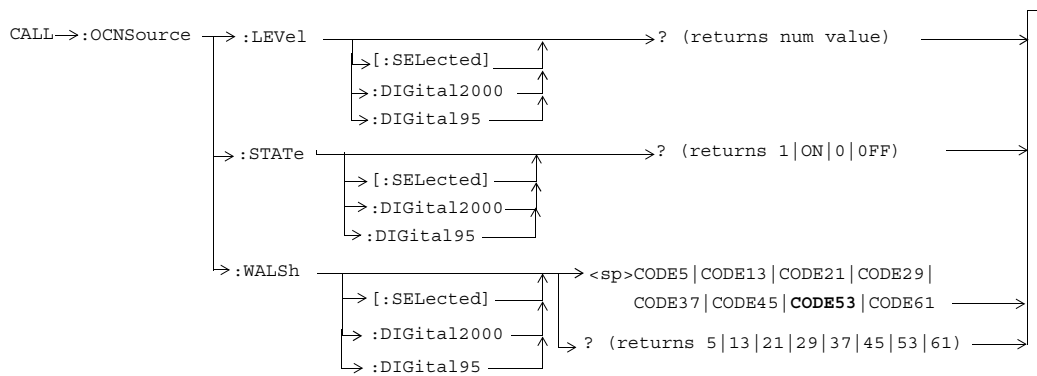

CALL[:CELL]:OPERating

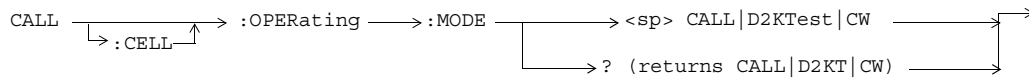

CALL:ORIGinate

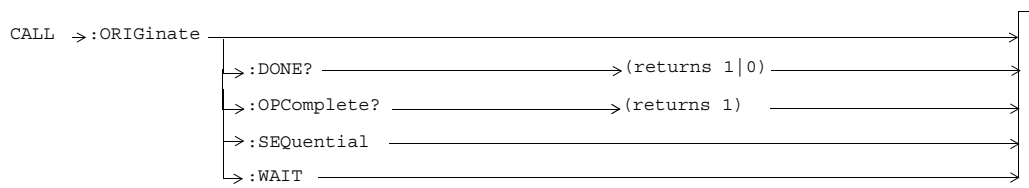

CALL:PAGing

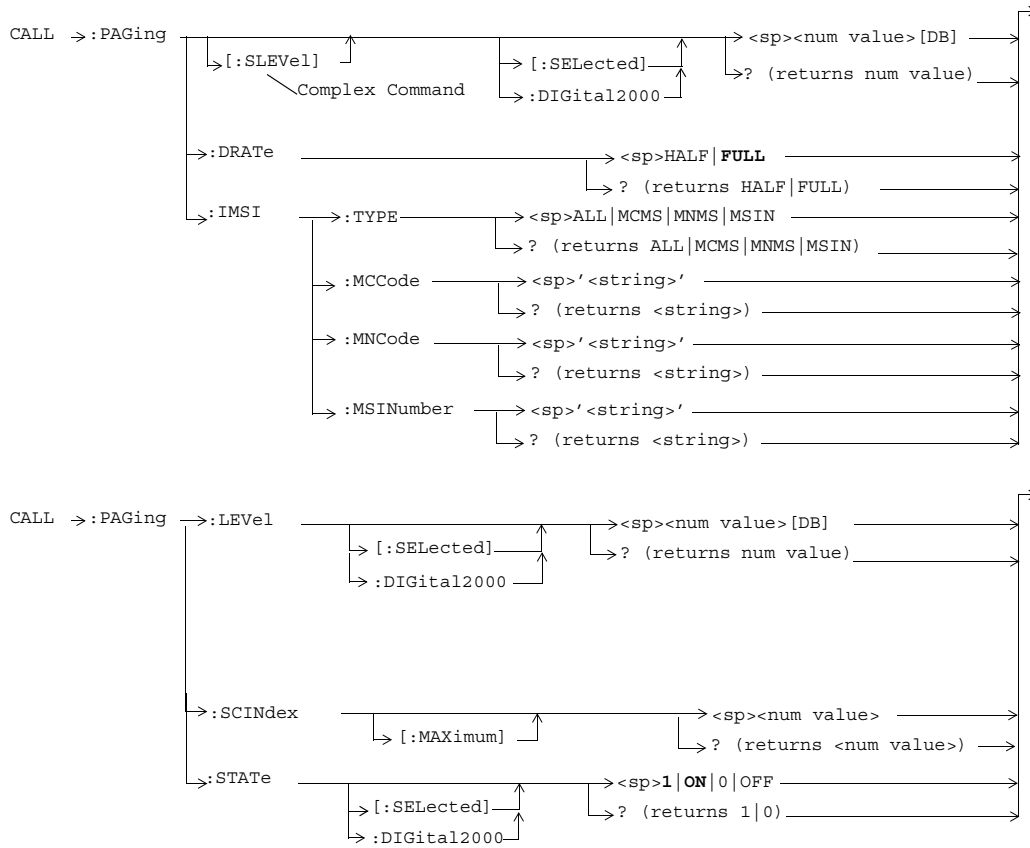

CALL:PILot

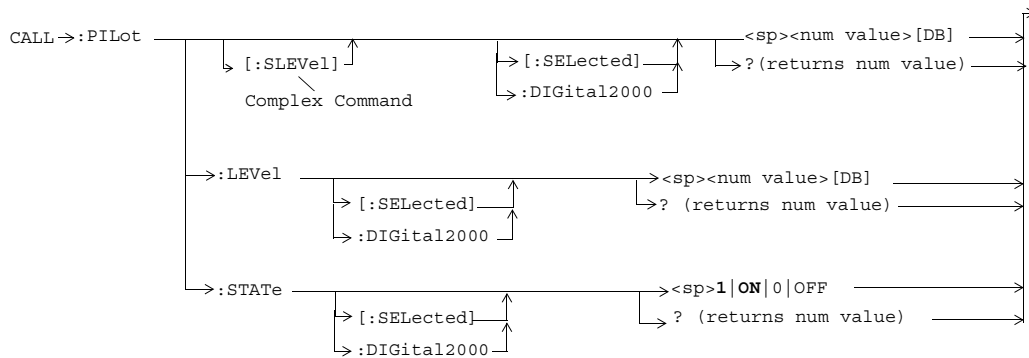

CALL[:CELL]:PNOffset

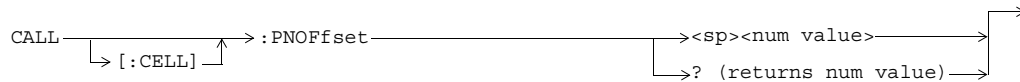

CALL[:CELL]:POWer

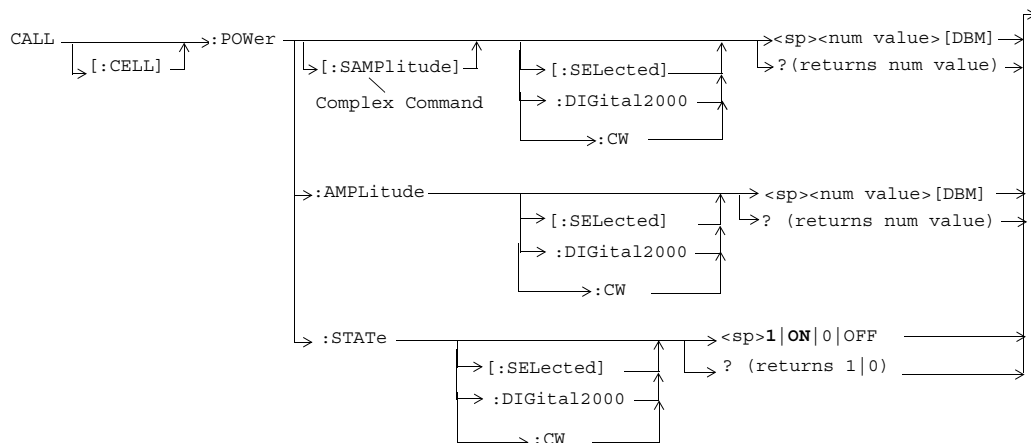

CALL[:CELL]:PROTOcol

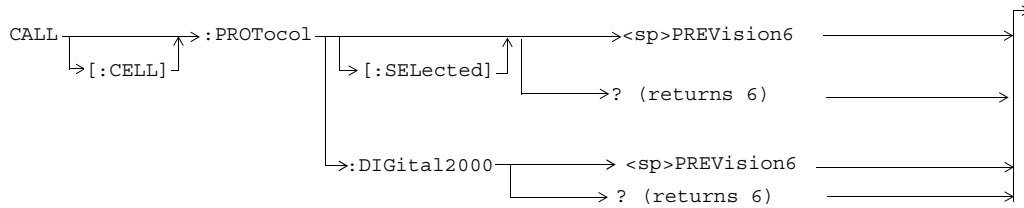

CALL:QPCHannel

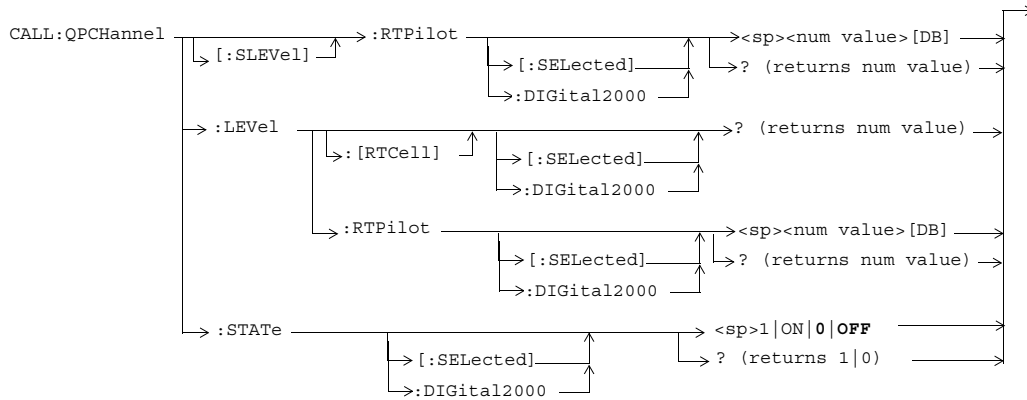

CALL[:CELL]:RCONfig

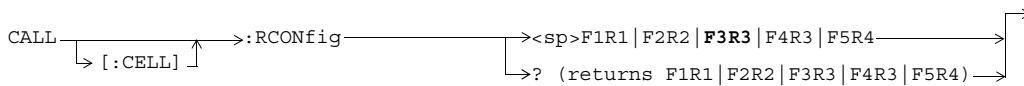

CALL:REGister

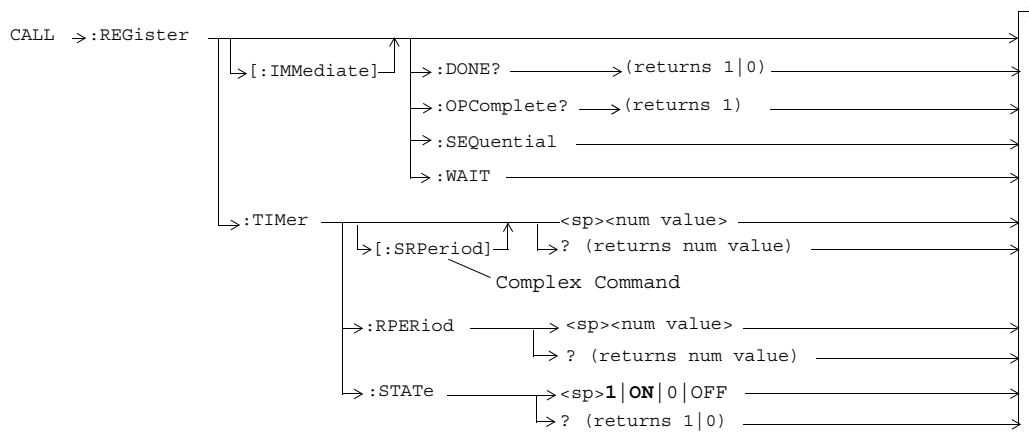

CALL[:CELL]:RFGenerator

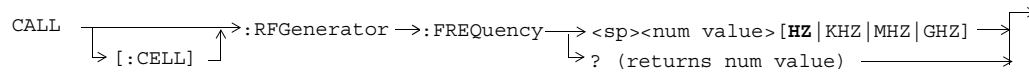

CALL[:CELL]:RLGain

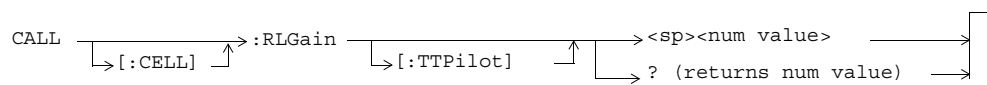

CALL:Schannel

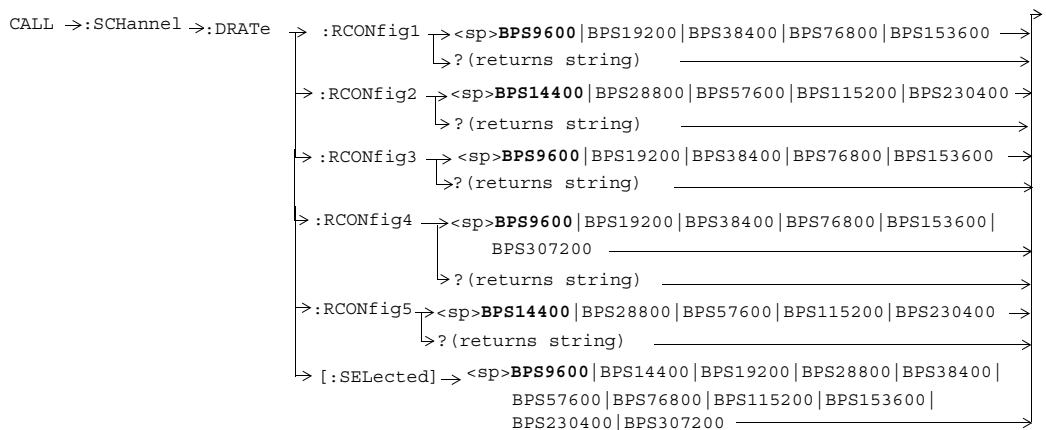
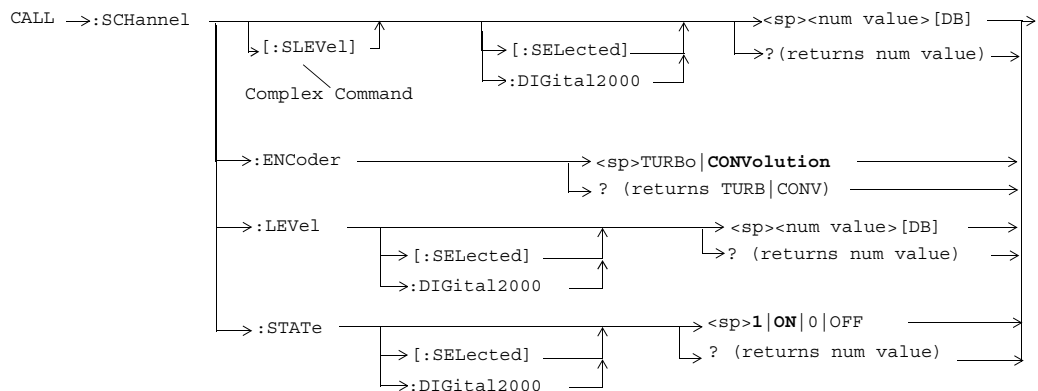

Note: Data rates used with the SElected keyword must be compatible with the currently selected radio configuration. If a data rate that does not belong to the selected radio configuration's rate set is used, an error message will be generated.

CALL:SETup:BAND

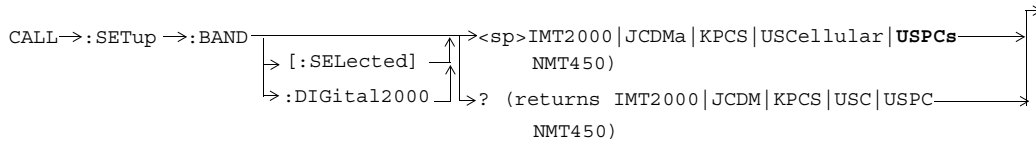

CALL:SETup:CHANnel

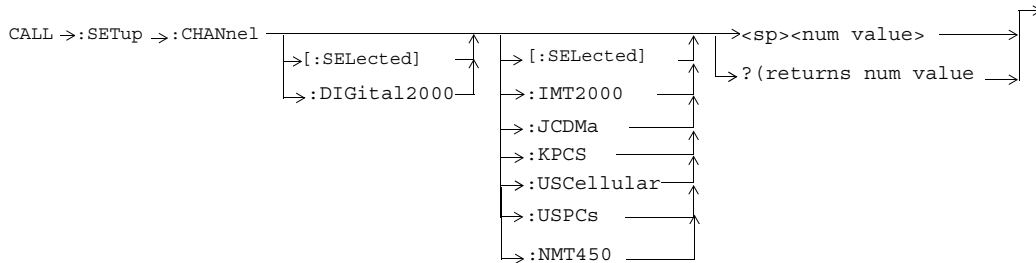

CALL:SETup:HANDoff

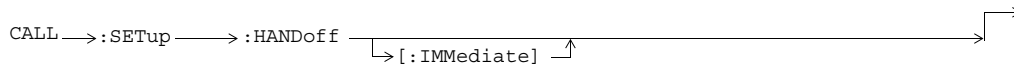

CALL:SETup:SYSTem

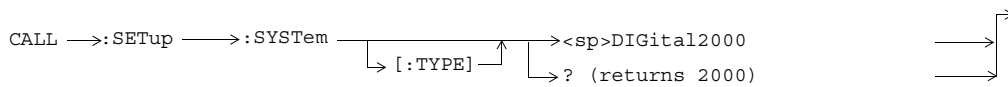

CALL[:CELL]:SIDentity

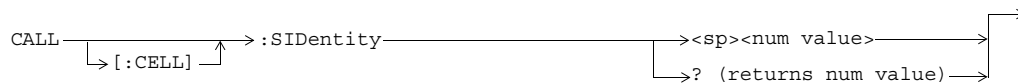

CALL[:CELL]:SOPTION

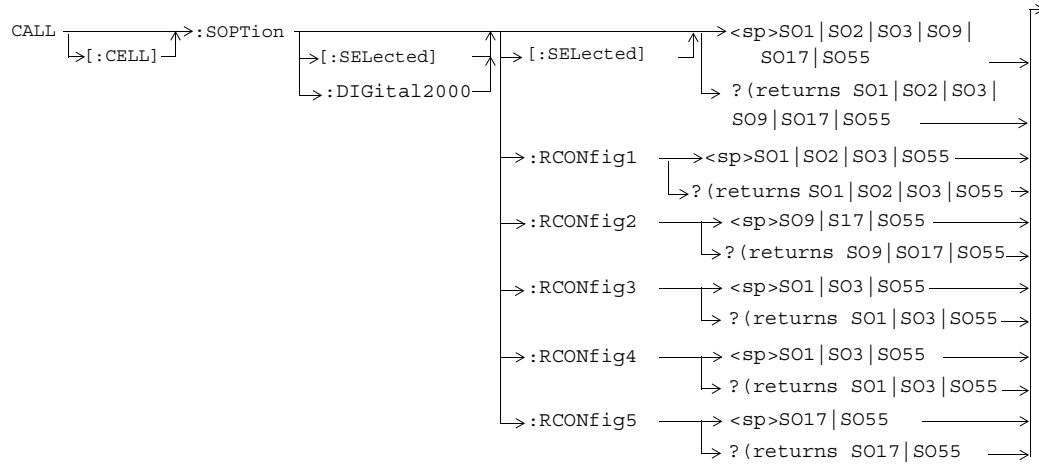

CALL:STATUs

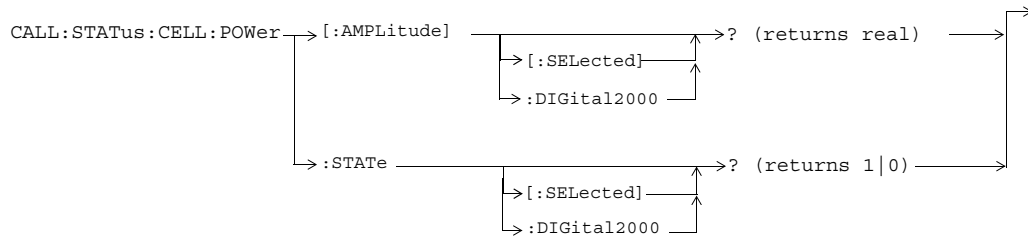
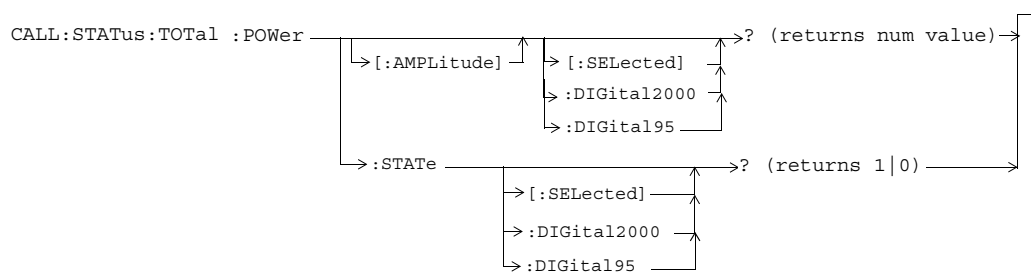
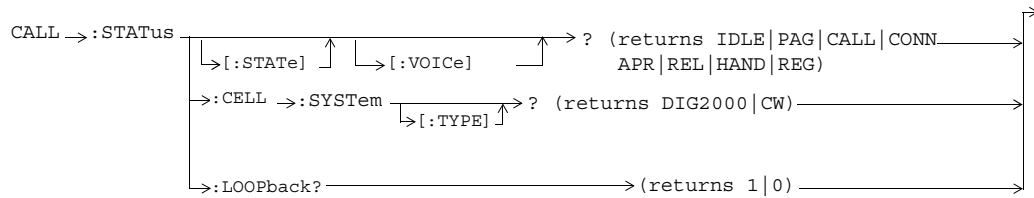

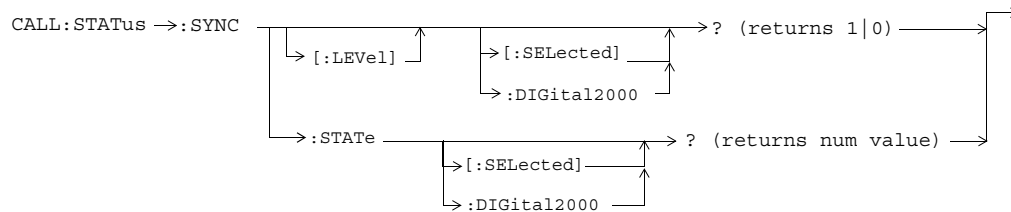
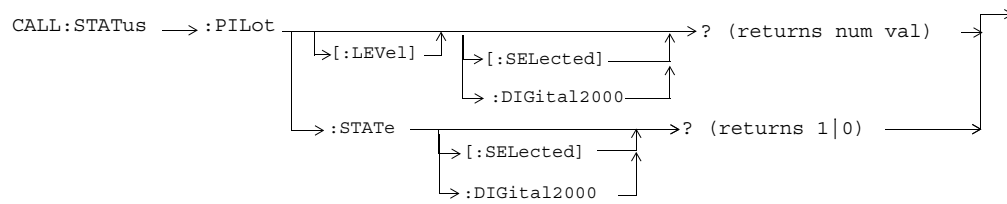
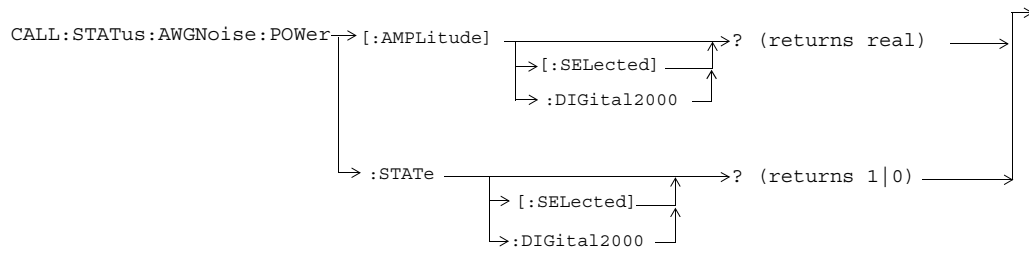

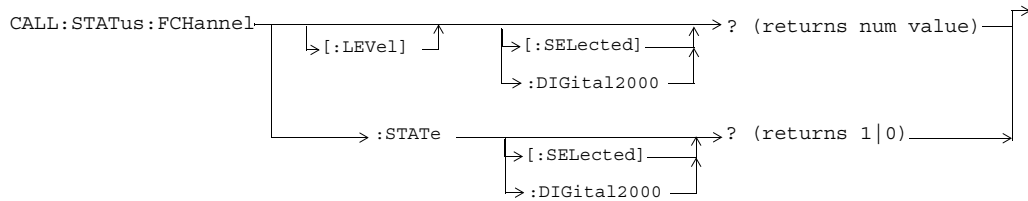
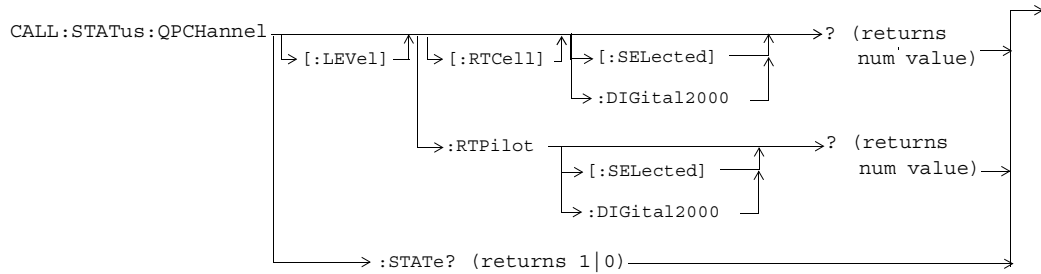
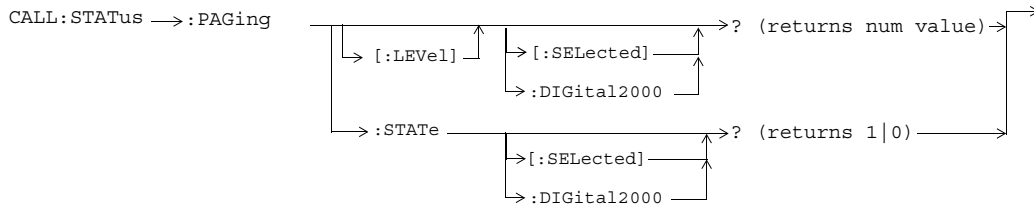

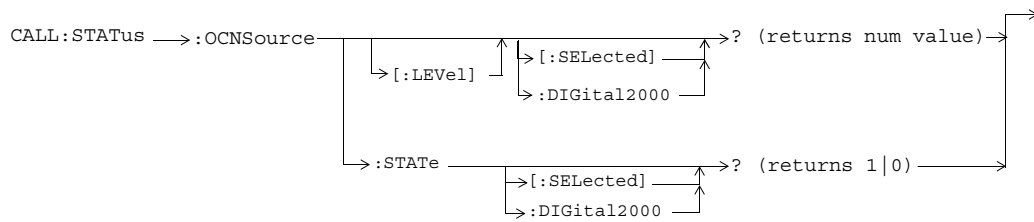
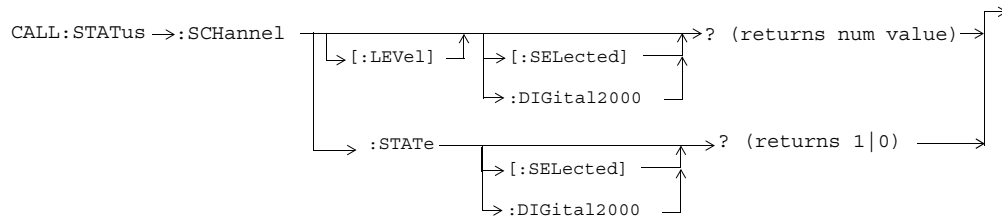

CALL:SYNC

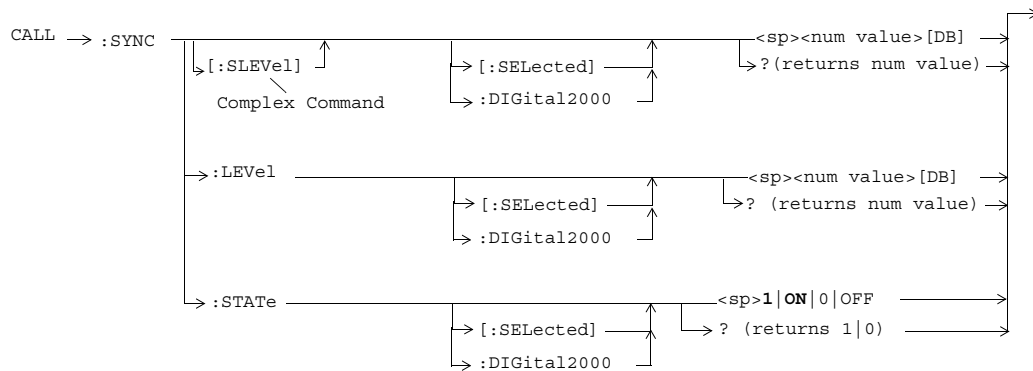

CALL[:CELL]:SYSTEM

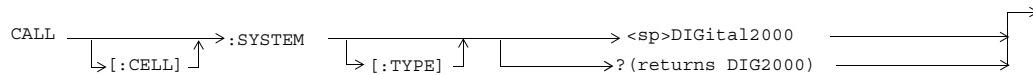

CALL:TOTAl:POWer

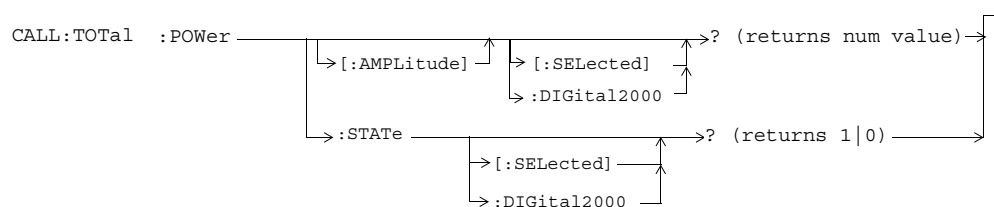

CALL:TRAFfic



CALL:TRIGger:TYPE

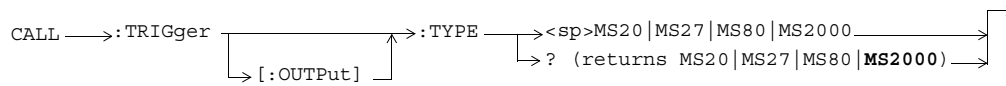

DISPlay

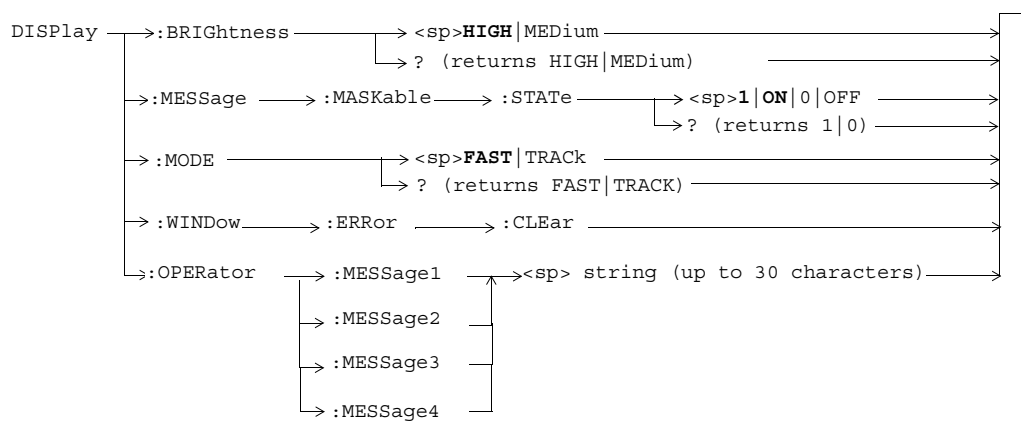

FETCH:CAPPower

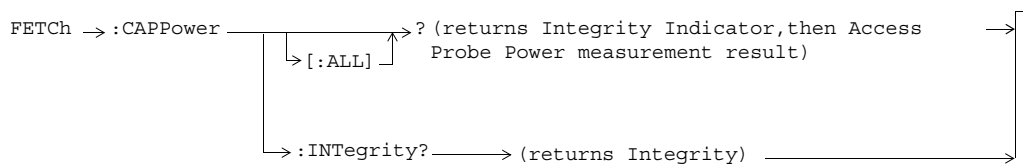

FETCh:CPOWer

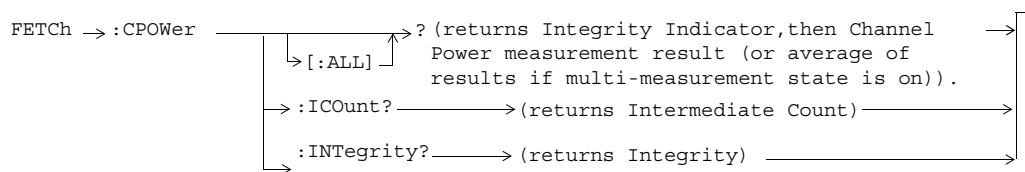

FETCh:DAPower

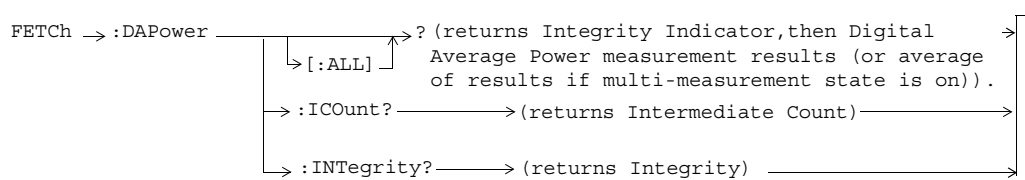

FETCh:CFERror

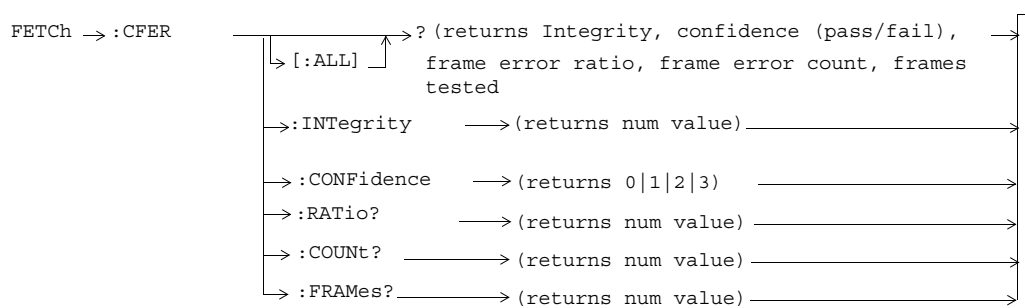

FETCH:FSTability

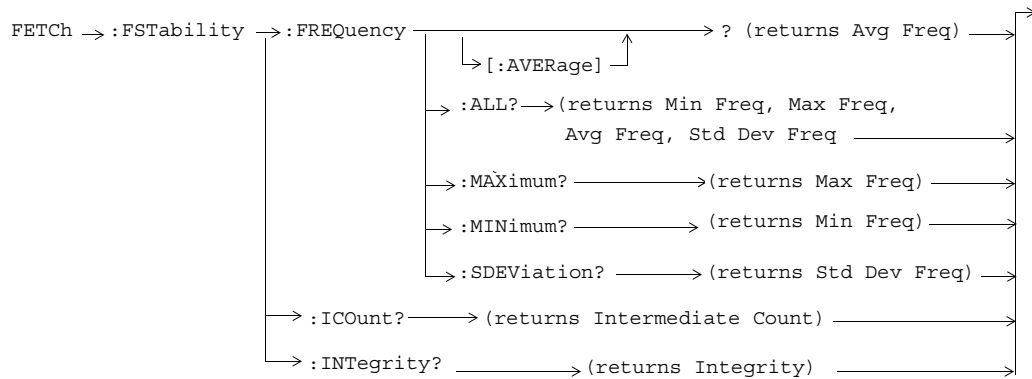
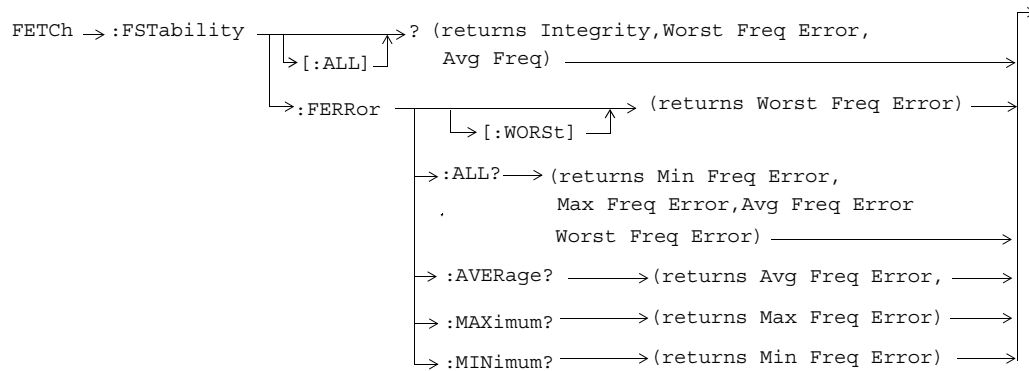

FETCH:WQuality

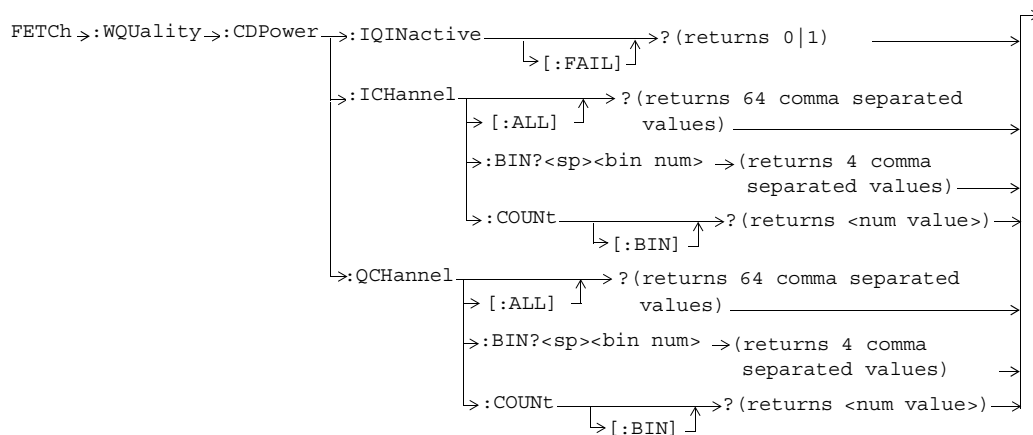
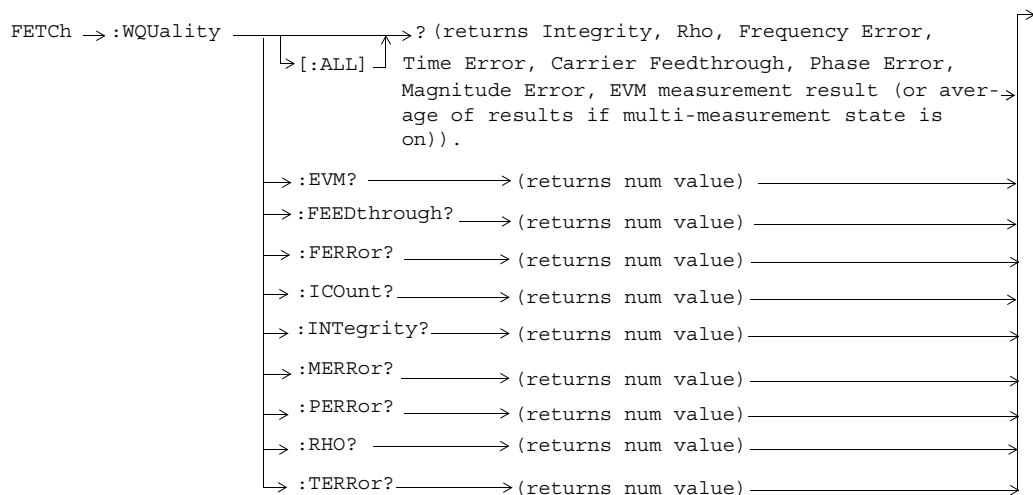

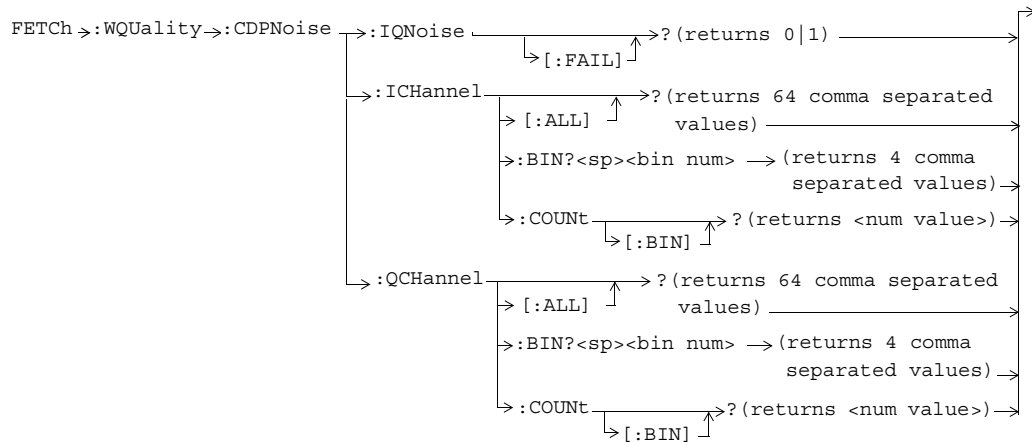

INITiate

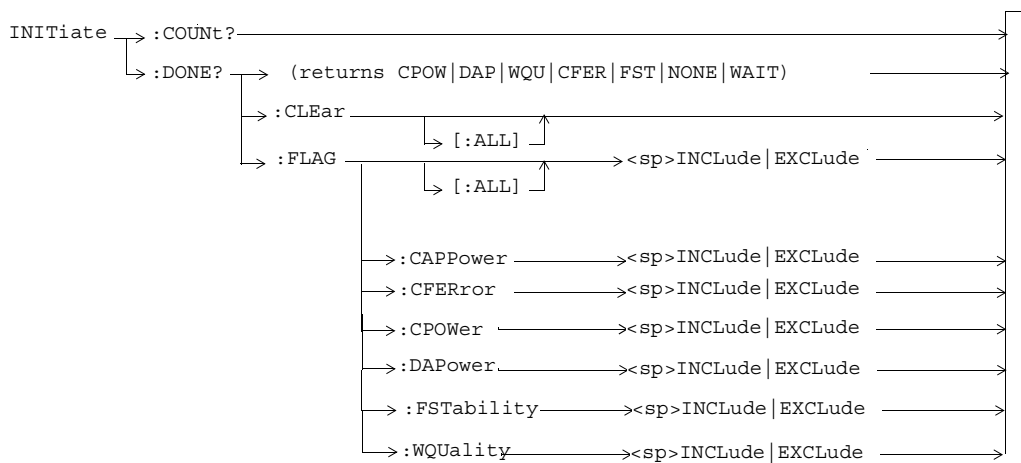
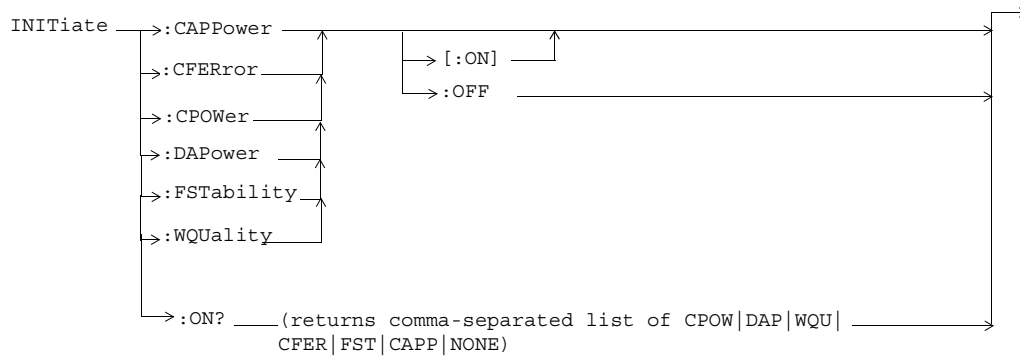

READ

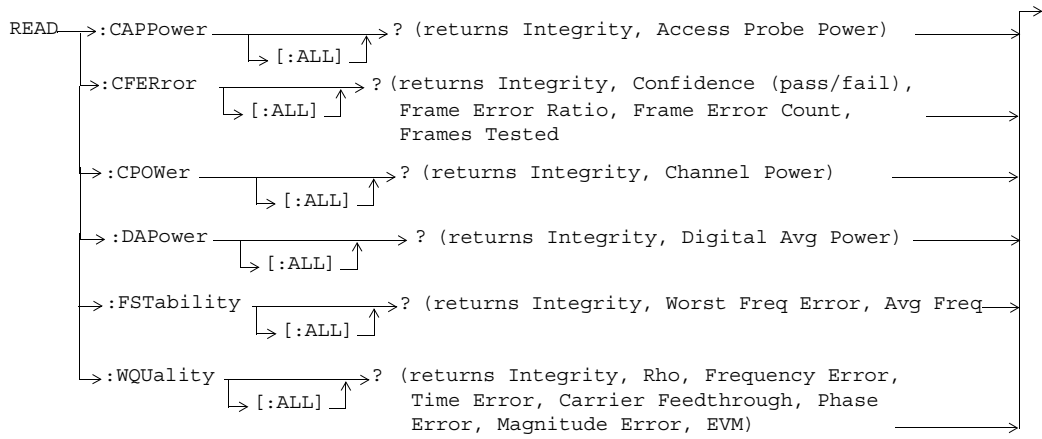

RFAnalyzer

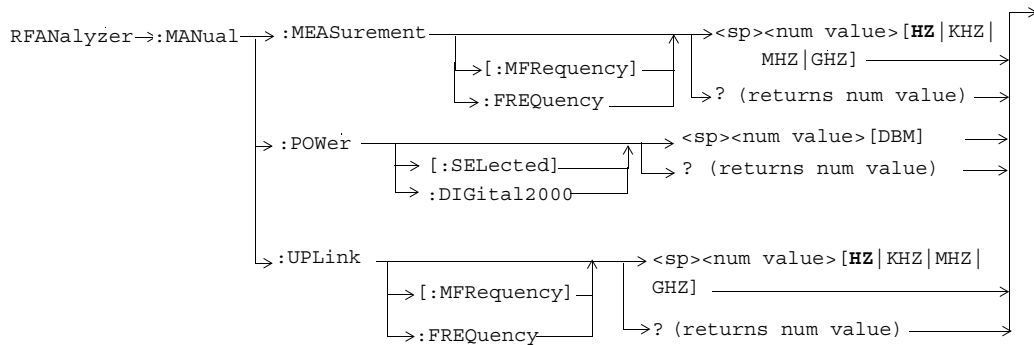
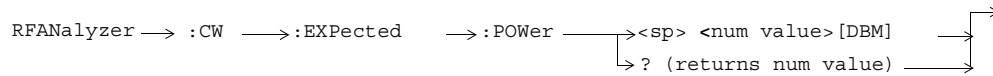
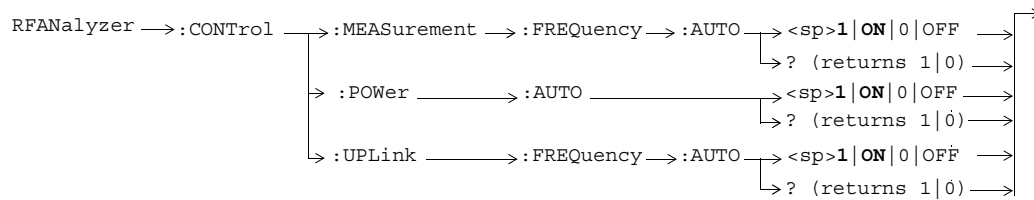
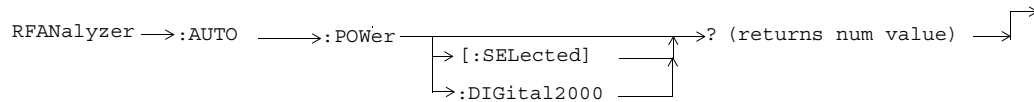

SETup[:ALL]:CONTinuous

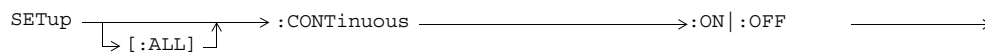

SETup:CAPPower

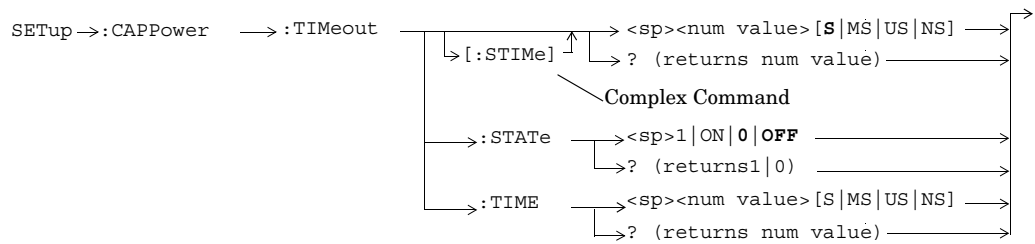
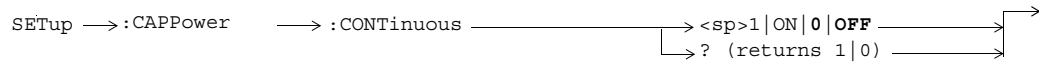

SETup:CFERror

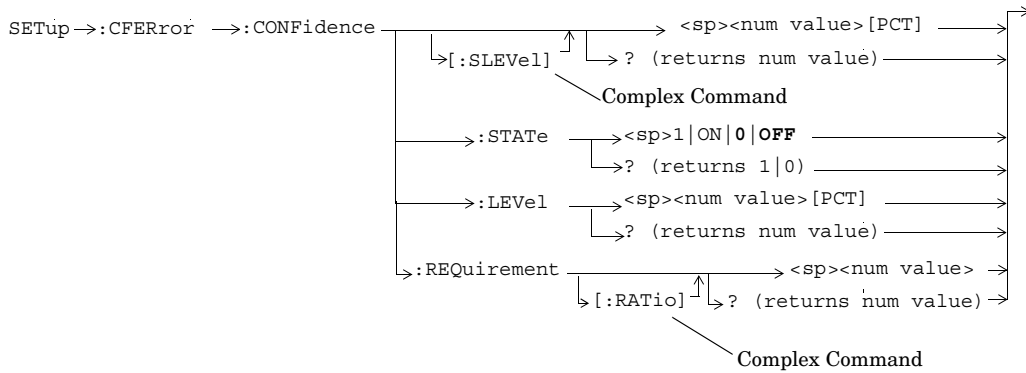
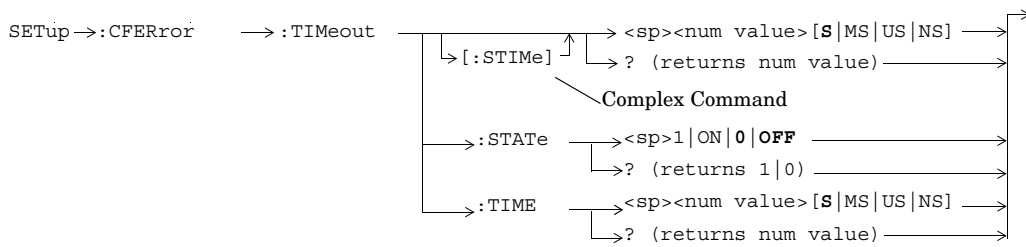
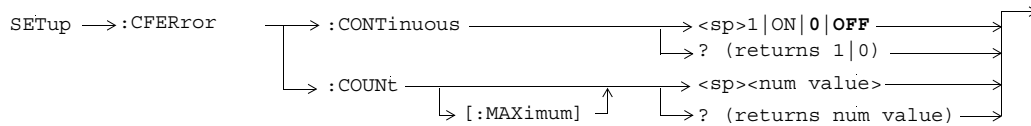

SETup:CPOWER

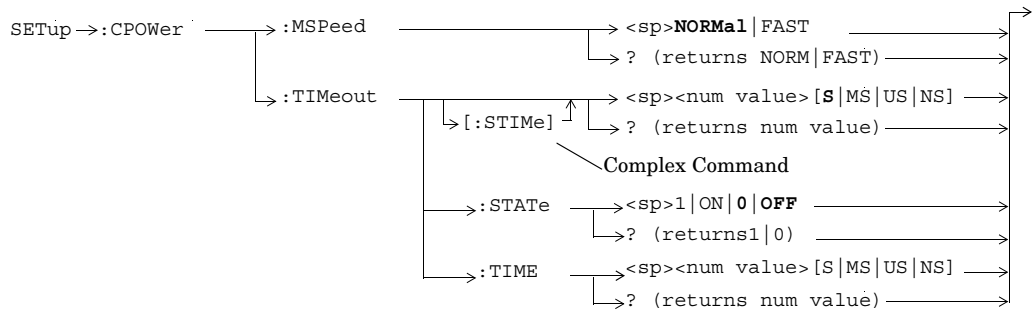
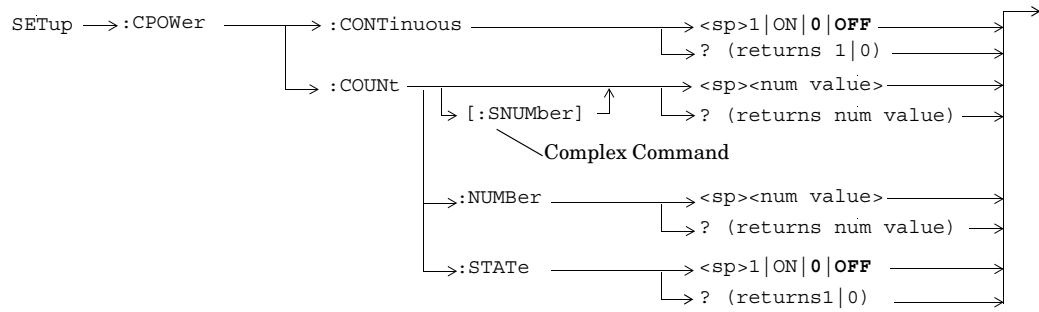

SETup:DAPower

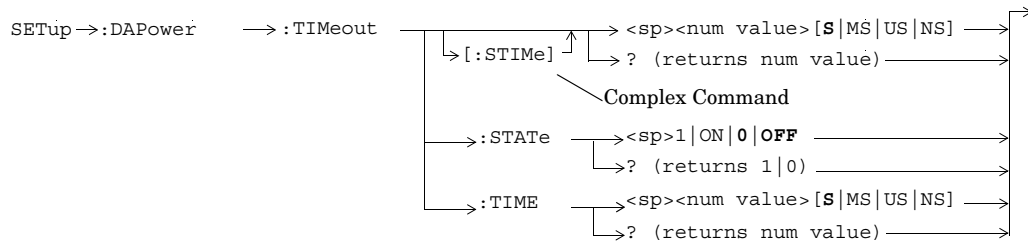
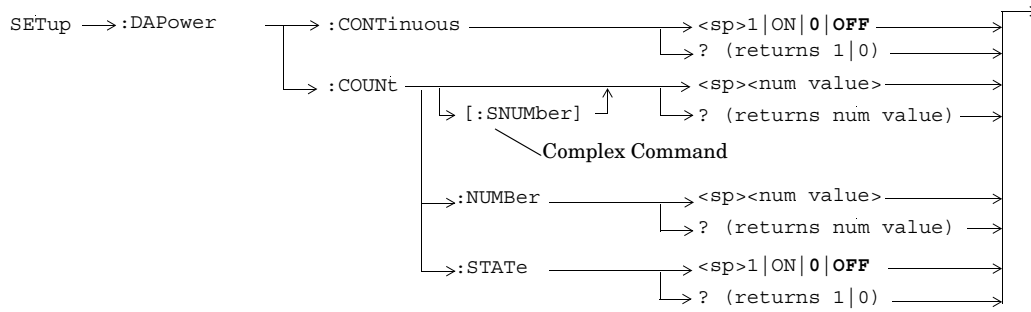

SETup:FSTability

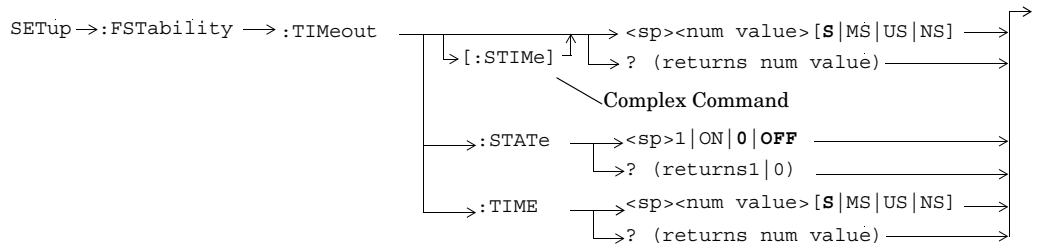
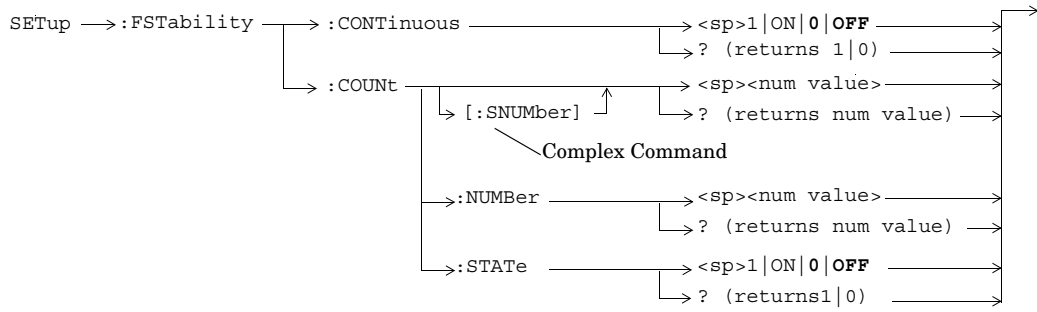

SETup:WQuality

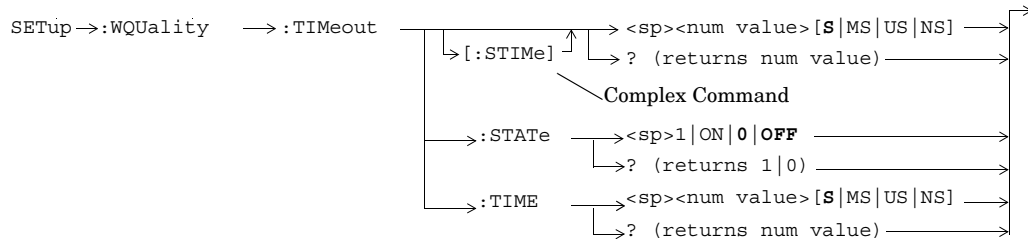
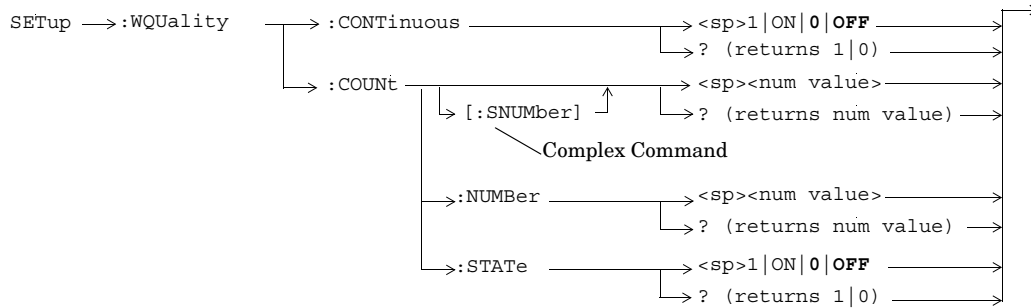
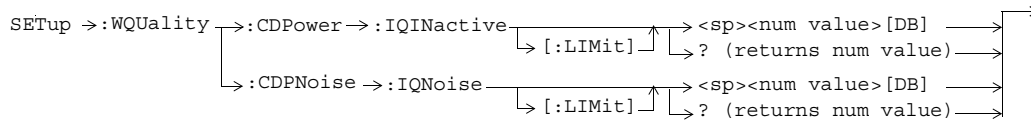

STATUS:OPERation:

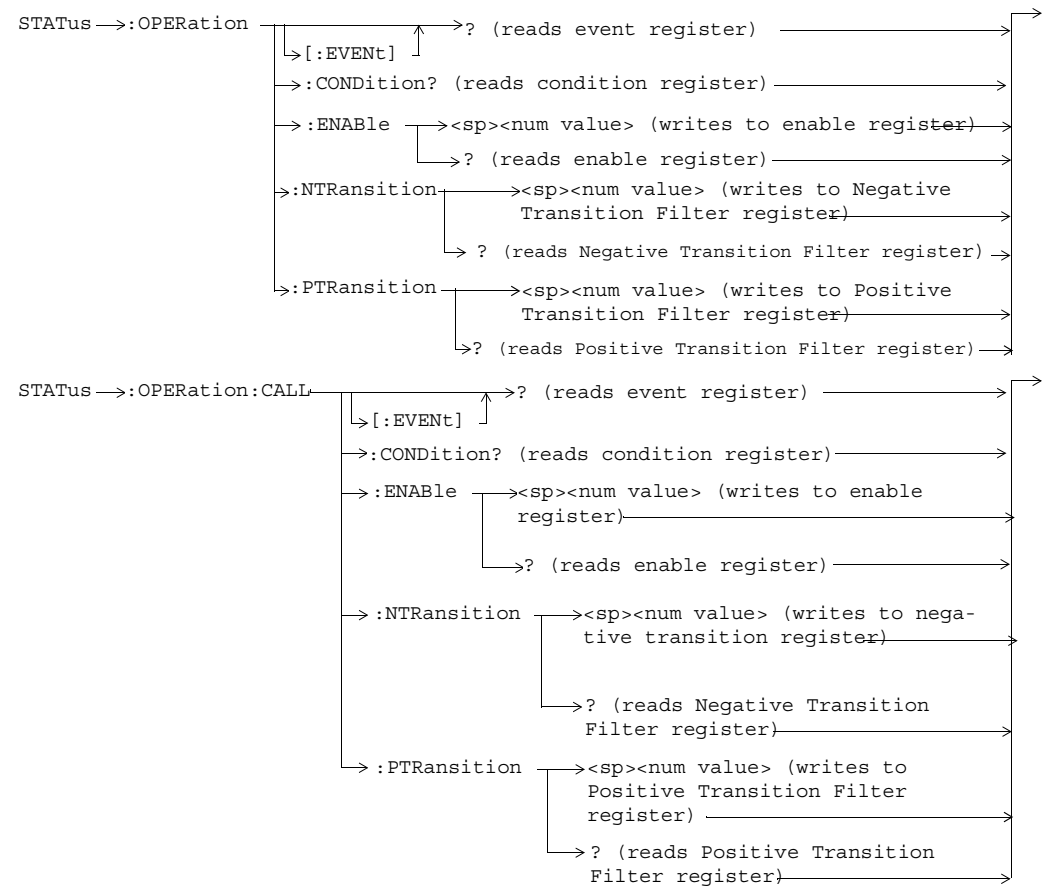

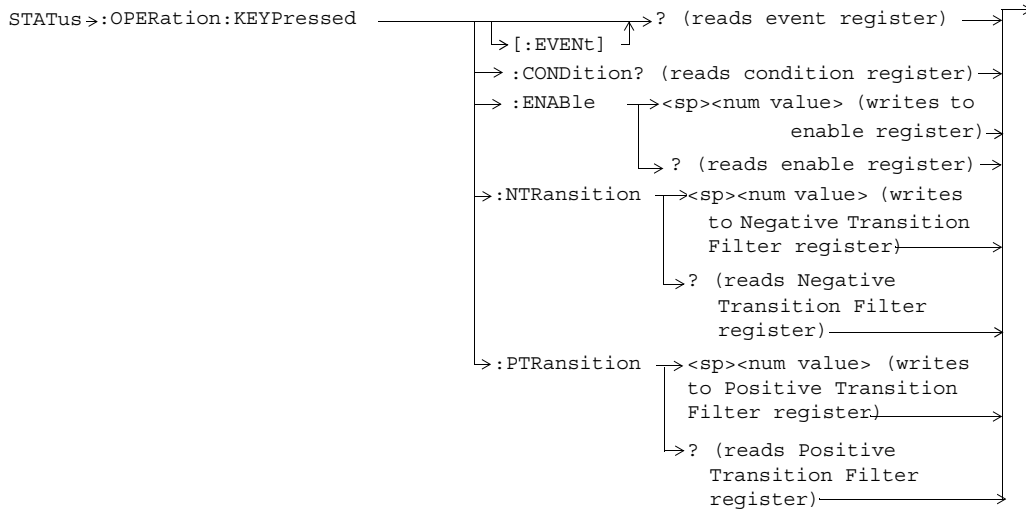
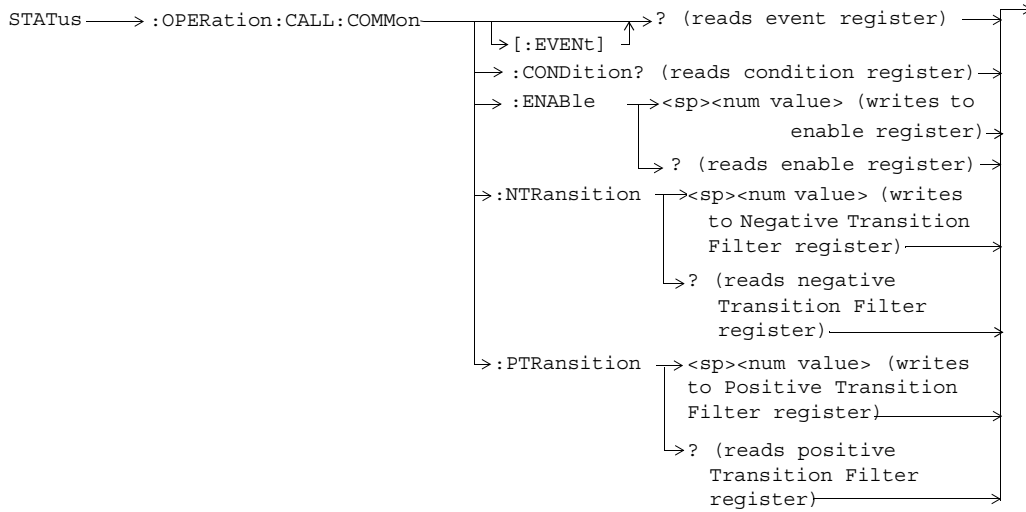

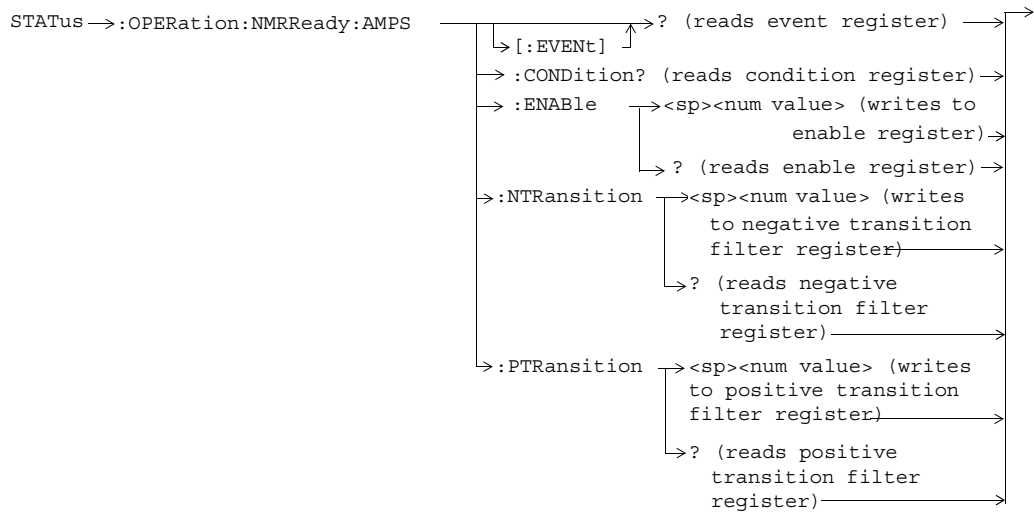
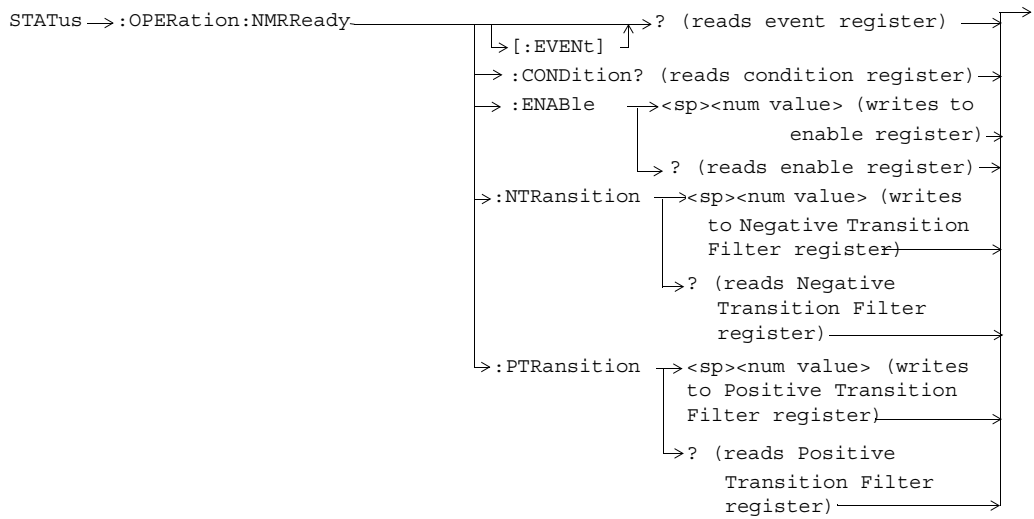

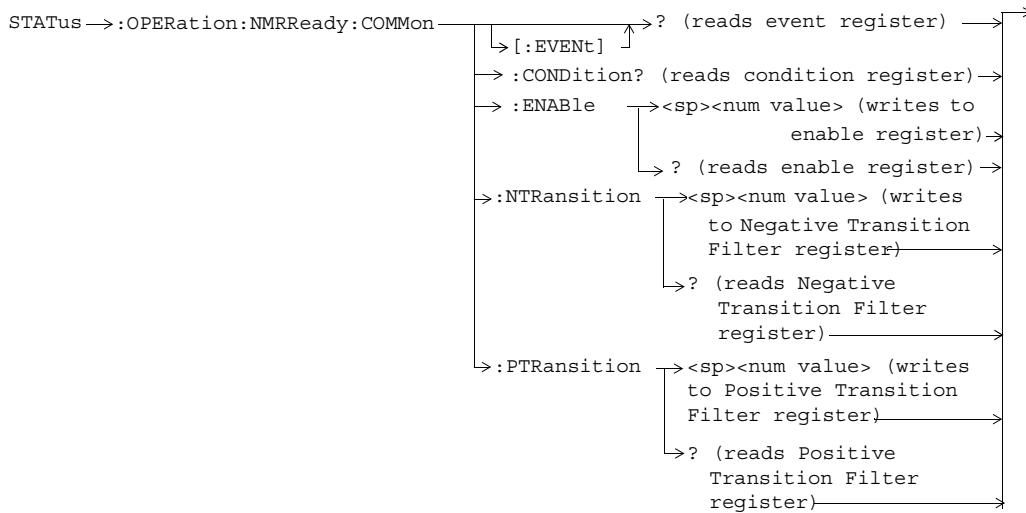
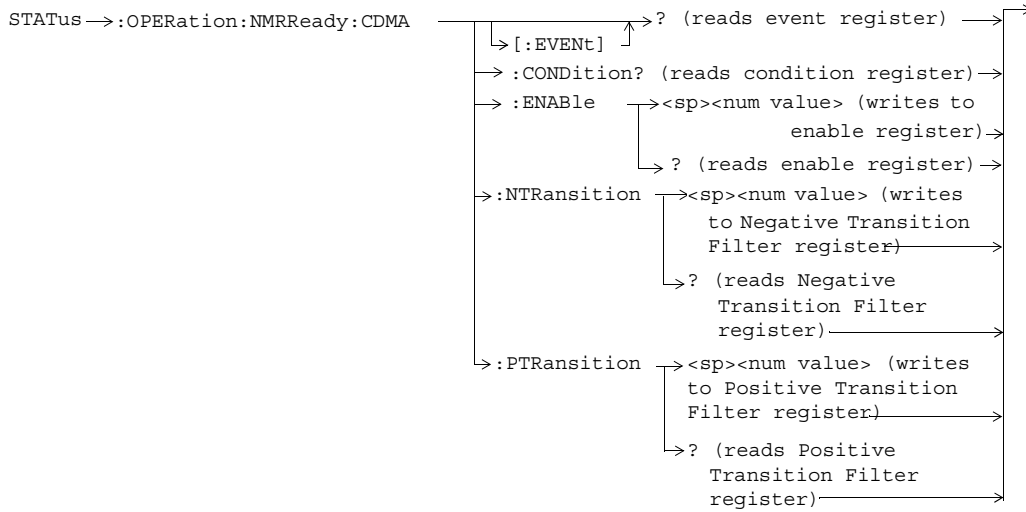

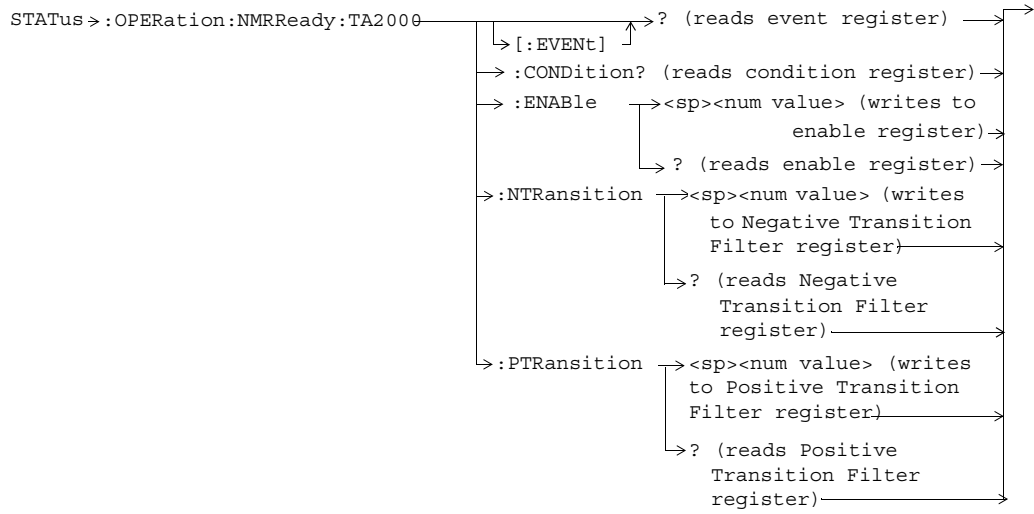
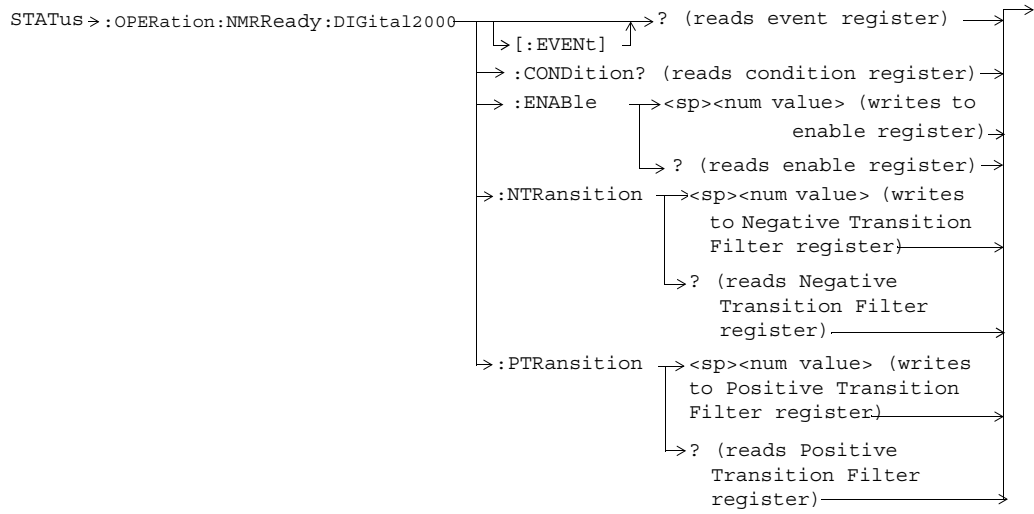

STATUS:PRESet

STATUS → :PRESet →

STATUS:QUESTIONable

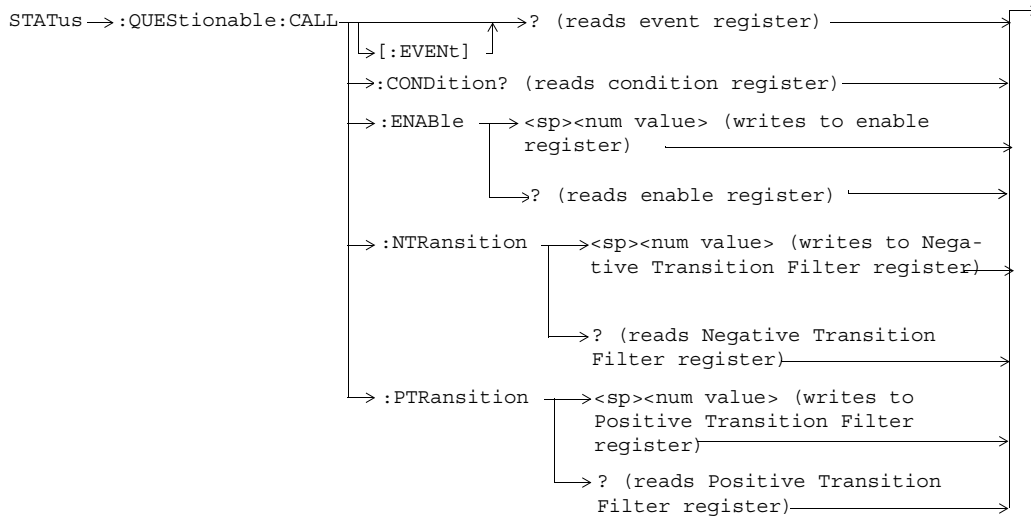
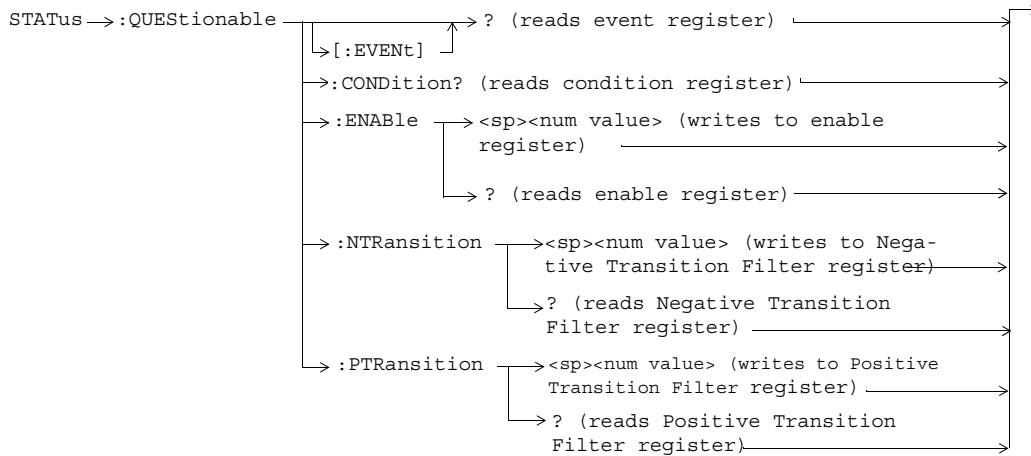

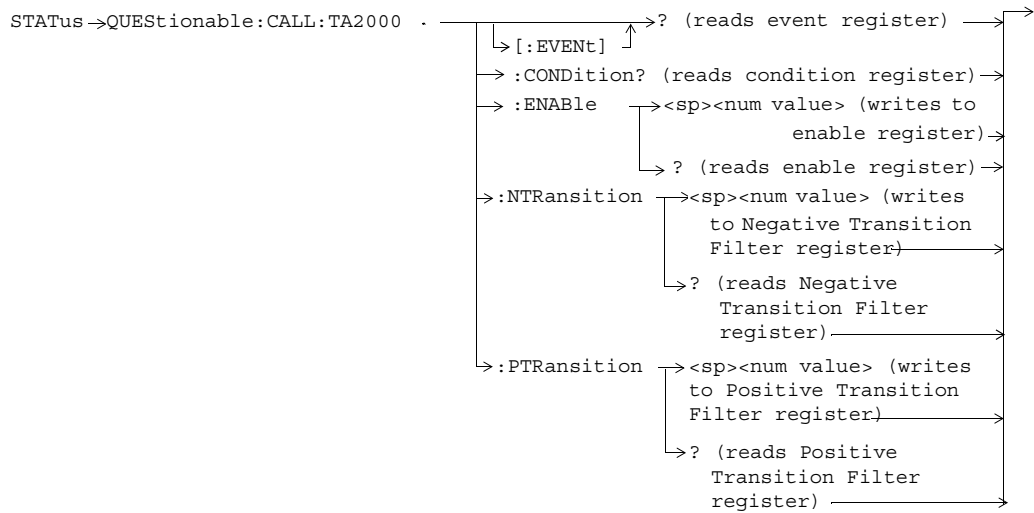
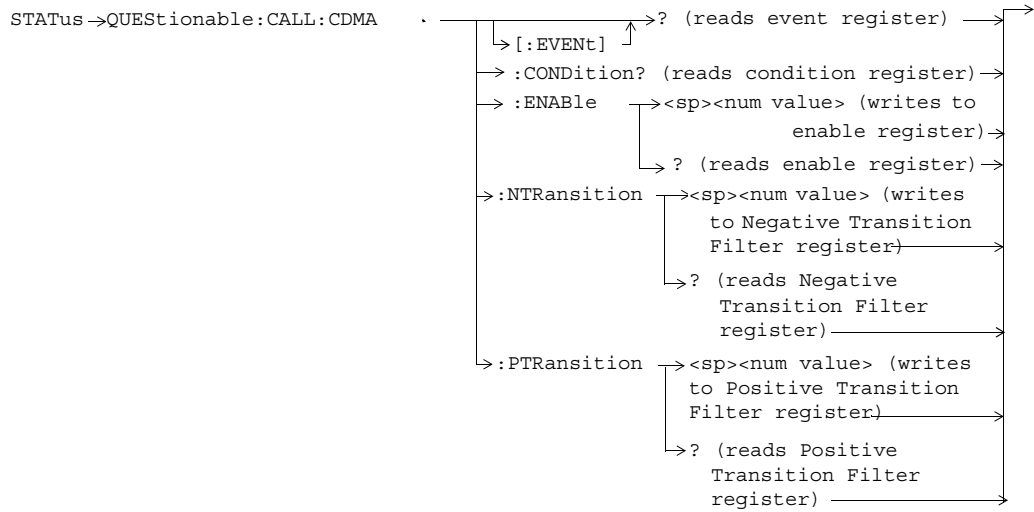

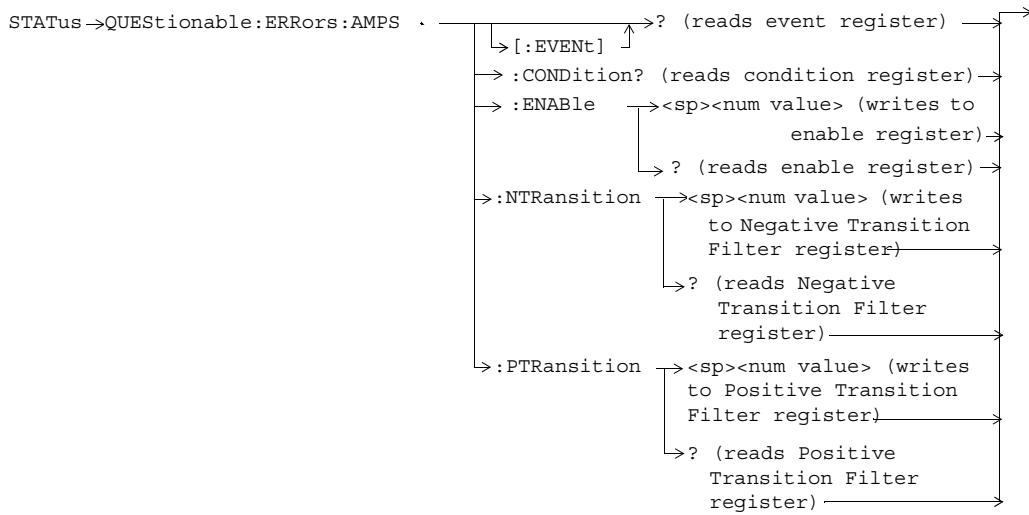
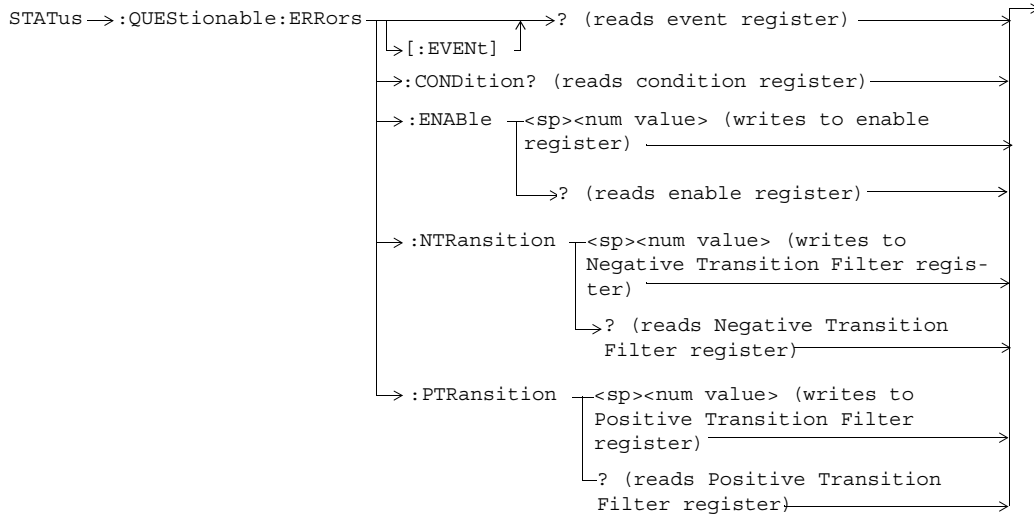

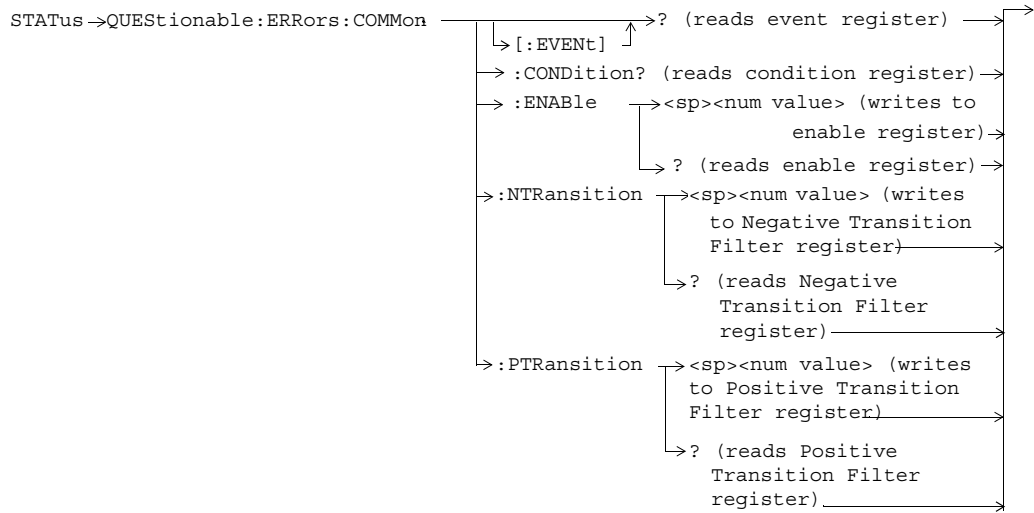
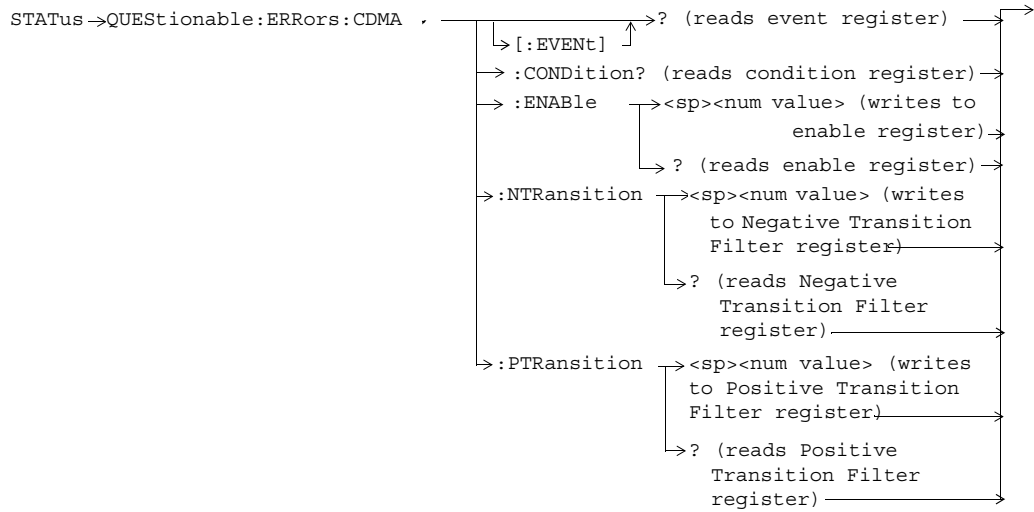

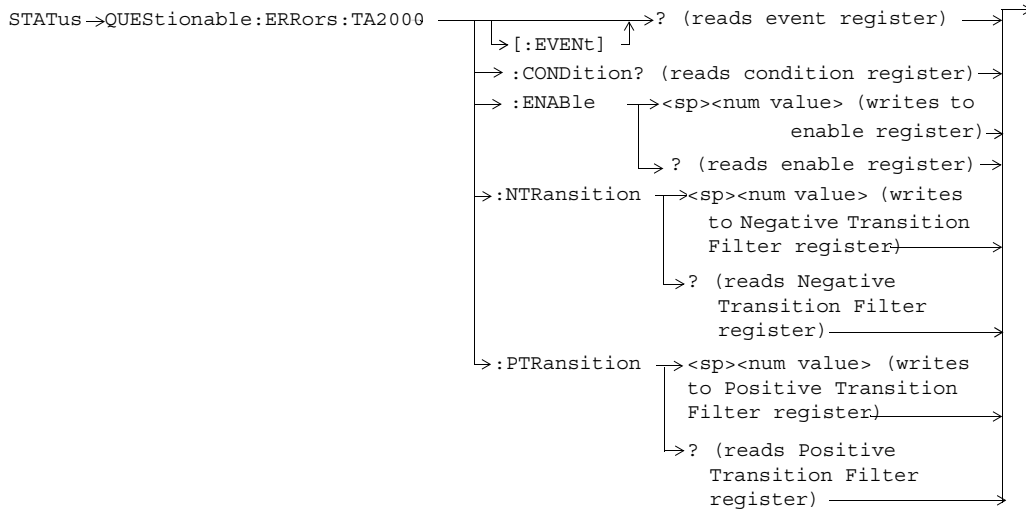
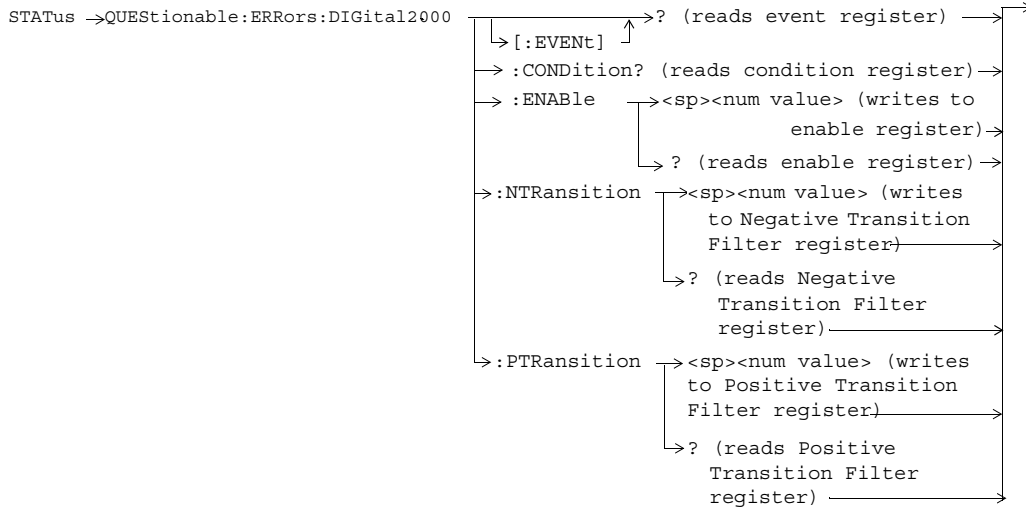

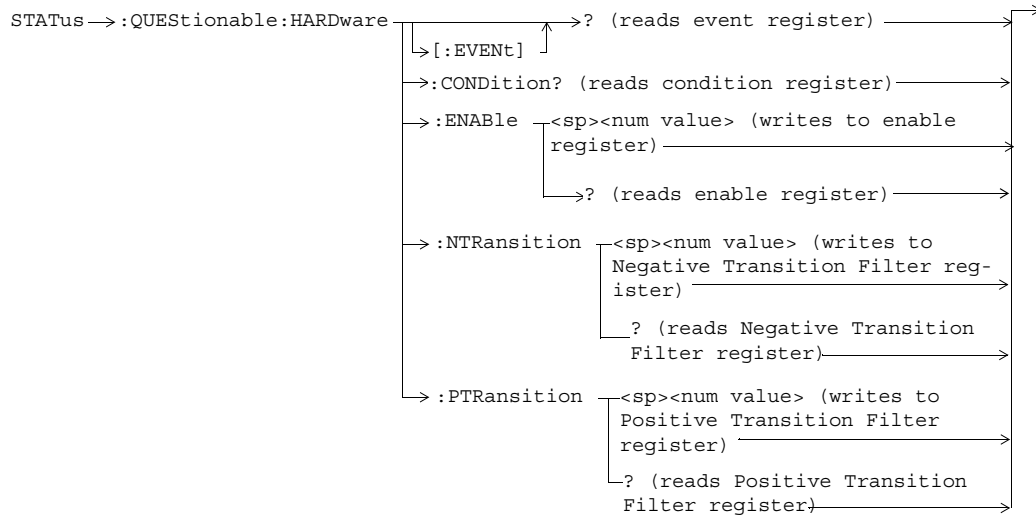

```

OUTPUT 714;"STATUS:QUESTIONABLE:EVENT?" !Queries and clears the Questionable Event
!Register
OUTPUT 714;"STATUS:QUESTIONABLE:CONDITION?" !Queries and clears the Questionable Condition
!Register
OUTPUT 714;"STATUS:QUESTIONABLE:ENABLE 1024" !Sets the Questionable Enable Register
!for bit 10
OUTPUT 714;"STATUS:QUESTIONABLE:NTRANSITION 2" !Sets the Questionable Negative
!Transition Filter Register for bit 1
OUTPUT 714;"STATUS:QUESTIONABLE:PTRANSITION 2" !Sets the Questionable Positive
!Transition Filter Register for bit 1

OUTPUT 714;"STATUS:QUESTIONABLE:CALL:EVENT?" !Queries and clears the Questionable
!Call Event Register
OUTPUT 714;"STATUS:QUESTIONABLE:CALL:CONDITION?" !Queries and clears the Questionable
!Call Condition Register
OUTPUT 714;"STATUS:QUESTIONABLE:CALL:ENABLE 1024" !Sets the Questionable
!Call Enable Register for bit 10
OUTPUT 714;"STATUS:QUESTIONABLE:CALL:NTRANSITION 2" !Sets the Questionable Call
!Negative Transition Filter Register
!for bit 1
OUTPUT 714;"STATUS:QUESTIONABLE:CALL:PTRANSITION 2" !Sets the Questionable Call
!Positive Transition Filter Register
!for bit 1

```

```

OUTPUT 714;"STATUS:QUESTIONABLE:CALL:CDMA:EVENT?" !Queries and clears the Questionable
!Call CDMA Event Register
OUTPUT 714;"STATUS:QUESTIONABLE:CALL:CDMA:CONDITION?" !Queries and clears the Questionable
!Call CDMA Condition Register
OUTPUT 714;"STATUS:QUESTIONABLE:CALL:CDMA:ENABLE 1024" !Sets the Questionable
!Call CDMA Enable Register for bit 10
OUTPUT 714;"STATUS:QUESTIONABLE:CALL:CDMA:NTRANSITION 2" !Sets the Questionable Call CDMA
!Negative Transition Filter Register
!for bit 1
OUTPUT 714;"STATUS:QUESTIONABLE:CALL:CDMA:PTRANSITION 2" !Sets the Questionable Call CDMA
!Positive Transition Filter Register
!for bit 1

OUTPUT 714;"STATUS:QUESTIONABLE:CALL:TA2000:EVENT?" !Queries and clears the Questionable
!Call Event Register
OUTPUT 714;"STATUS:QUESTIONABLE:CALL:TA2000:CONDITION?" !Queries and clears the Questionable
!Call Condition Register
OUTPUT 714;"STATUS:QUESTIONABLE:CALL:TA2000:ENABLE 1024" !Sets the Questionable
!Call Enable Register for bit 10
OUTPUT 714;"STATUS:QUESTIONABLE:CALL:TA2000:NTRANSITION 2" !Sets the Questionable Call
!Negative Transition Filter Register
!for bit 1
OUTPUT 714;"STATUS:QUESTIONABLE:CALL:TA2000:PTRANSITION 2" !Sets the Questionable Call
!Positive Transition Filter Register
!for bit 1

OUTPUT 714;"STATUS:QUESTIONABLE:ERRORS:EVENT?" !Queries and clears the Questionable
!Errors Event Register
OUTPUT 714;"STATUS:QUESTIONABLE:ERRORS:CONDITION?" !Queries and clears the Questionable
!Errors Condition Register
OUTPUT 714;"STATUS:QUESTIONABLE:ERRORS:ENABLE 1024" !Sets the Questionable
!Errors Enable
!Register for bit 10
OUTPUT 714;"STATUS:QUESTIONABLE:ERRORS:NTRANSITION 2" !Sets the Questionable Errors
!Negative Transition Filter Register
!for bit 1
OUTPUT 714;"STATUS:QUESTIONABLE:ERRORS:PTRANSITION 2" !Sets the Questionable Errors
!Positive Transition Filter Register
!for bit 1

```

```

OUTPUT 714;"STATUS:QUESTIONABLE:ERRORS:AMPS:EVENT?" !Queries and clears the Questionable
!Errors AMPS Event Register
OUTPUT 714;"STATUS:QUESTIONABLE:ERRORS:AMPS:CONDITION?" !Queries and clears the Questionable
!Errors AMPS Condition Register
OUTPUT 714;"STATUS:QUESTIONABLE:ERRORS:AMPS:ENABLE 1024" !Sets the Questionable
!Errors AMPS Enable
!Register for bit 10
OUTPUT 714;"STATUS:QUESTIONABLE:ERRORS:AMPS:NTRANSITION 2" !Sets the Questionable Errors
!AMPS Negative Transition
!Filter Register for bit 1
OUTPUT 714;"STATUS:QUESTIONABLE:ERRORS:AMPS:PTRANSITION 2" !Sets the Questionable Errors
!AMPS Positive Transition
!Filter Register for bit 1

OUTPUT 714;"STATUS:QUESTIONABLE:ERRORS:CDMA:EVENT?" !Queries and clears the Questionable
!Errors CDMA Event Register
OUTPUT 714;"STATUS:QUESTIONABLE:ERRORS:CDMA:CONDITION?" !Queries and clears the Questionable
!Errors CDMA Condition Register
OUTPUT 714;"STATUS:QUESTIONABLE:ERRORS:CDMA:ENABLE 1024" !Sets the Questionable
!Errors CDMA Enable
!Register for bit 10
OUTPUT 714;"STATUS:QUESTIONABLE:ERRORS:CDMA:NTRANSITION 2" !Sets the Questionable Errors
!CDMA Negative Transition
!Filter Register for bit 1
OUTPUT 714;"STATUS:QUESTIONABLE:ERRORS:CDMA:PTRANSITION 2" !Sets the Questionable Errors
!CDMA Positive Transition
!Filter Register for bit 1

OUTPUT 714;"STATUS:QUESTIONABLE:ERRORS:COMMON:EVENT?" !Queries and clears the Questionable
!Errors Common Event Register
OUTPUT 714;"STATUS:QUESTIONABLE:ERRORS:COMMON:CONDITION?" !Queries the and clears the
!Questionable Errors
!Common Condition Register
OUTPUT 714;"STATUS:QUESTIONABLE:ERRORS:COMMON:ENABLE 1024" !Sets the Questionable
!Errors Common Enable
!Register for bit 10
OUTPUT 714;"STATUS:QUESTIONABLE:ERRORS:COMMON:NTRANSITION 2" !Sets the Questionable Errors
!Common Negative Transition
!Register for bit 1
OUTPUT 714;"STATUS:QUESTIONABLE:ERRORS:COMMON:PTRANSITION 2" !Sets the Questionable Errors
!Common Positive Transition
!Register for bit 1

```

```

OUTPUT 714;"STATUS:QUESTIONABLE:ERRORS:DIGITAL2000:EVENT?" !Queries and clears the
!Questionable Errors
!DIGITAL2000 Event Register
OUTPUT 714;"STATUS:QUESTIONABLE:ERRORS:DIGITAL2000:CONDITION?" !Queries and clears the
!Questionable Errors
!DIGITAL2000 Condition Register
OUTPUT 714;"STATUS:QUESTIONABLE:ERRORS:DIGITAL2000:ENABLE 1024" !Sets the Questionable
!Errors DIGITAL2000 Enable
!Register for bit 10
OUTPUT 714;"STATUS:QUESTIONABLE:ERRORS:DIGITAL2000:NTRANSITION 2" !Sets the Questionable
!Errors DIGITAL2000 Negative
!Transition Filter
!Register for bit 1
OUTPUT 714;"STATUS:QUESTIONABLE:ERRORS:DIGITAL2000:PTRANSITION 2" !Sets the Questionable
!Errors DIGITAL2000 Positive
!Transition Filter
!Register for bit 1

OUTPUT 714;"STATUS:QUESTIONABLE:ERRORS:TA2000:EVENT?" !Queries and clears the
!Questionable Errors
!TA2000 Event Register
OUTPUT 714;"STATUS:QUESTIONABLE:ERRORS:TA2000:CONDITION?" !Queries and clears the
!Questionable Errors
!TA2000 Condition Register
OUTPUT 714;"STATUS:QUESTIONABLE:ERRORS:TA2000:ENABLE 1024" !Sets the Questionable
!Errors TA2000 Enable
!Register for bit 10
OUTPUT 714;"STATUS:QUESTIONABLE:ERRORS:TA2000:NTRANSITION 2" !Sets the Questionable
!Errors TA2000 Negative
!Transition Filter
!Register for bit 1
OUTPUT 714;"STATUS:QUESTIONABLE:ERRORS:TA2000:PTRANSITION 2" !Sets the Questionable
!Errors TA2000 Positive
!Transition Filter
!Register for bit 1

OUTPUT 714;"STATUS:QUESTIONABLE:HARDWARE:EVENT?" !Queries and clears the Questionable
!Hardware Event Register
OUTPUT 714;"STATUS:QUESTIONABLE:HARDWARE:CONDITION?" !Queries and clears the Questionable
!Hardware Condition Register
OUTPUT 714;"STATUS:QUESTIONABLE:HARDWARE:ENABLE 1024" !Sets the Questionable
!Hardware Enable
!Register for bit 10
OUTPUT 714;"STATUS:QUESTIONABLE:HARDWARE:NTRANSITION 2" !Sets the Questionable
!Hardware Negative Transition Filter
!Register for bit 1
OUTPUT 714;"STATUS:QUESTIONABLE:HARDWARE:PTRANSITION 2" !Sets the Questionable
!Hardware Positive Transition Filter
!Register for bit 1

```

Status Byte Register

***STB?**

*STB? _____ ↘ →

NOTE The Status Byte Register can also be read with a serial poll. For example, the command “Status_byte = SPOLL(714)” would perform a serial poll of the Status Byte Register, returning and releasing RQS (bit 6).

Status Byte Register Bit Assignments

Bit Number	Binary Weighting	Label	Description
7	128	STATUS: OPERation	Summarizes the STATUS: OPERation Status Register, which fans out to the NMRReady and CALL Status Registers.
6	64	RQS (SRQ TRUE?)/Master Summary Status	RQS is read by a serial poll (SPOLL) Master Summary Status is read by a *STB? query - defined by IEEE 488.2
5	32	Standard Event Status Register	Summarizes the Standard Event Status Register
4	16	Message Available	SCPI - Defined
3	8	STATUS: QUEStionable Status Register	Summary Message comes from the STATUS: QUEStionable Status Register, which fans out to the CALL and HARDware Status Registers
2	4	Error/ Event Queue	SCPI - Defined
1	2	Reserved	
0	1	Reserved	

Standard Event Status Register

***ESR?**

*ESR? → Reads and clears the Std Event Status Register. →

***ESE?**

*ESE? → Reads the Std Event Status Register Enable Register →

***ESE**

*ESE → Writes to the Std Event Status Register Enable Register →

“Diagram Conventions” on page 7

Standard Event Status Register Bit Assignment

Bit Number	Binary Weighting	Condition	Description
15	32768	Reserved by IEEE.	This bit will always be 0.
14	16384	Reserved by IEEE.	This bit will always be 0.
13	8192	Reserved by IEEE.	This bit will always be 0.
12	4096	Reserved by IEEE.	This bit will always be 0.
11	2048	Reserved by IEEE.	This bit will always be 0.
10	1024	Reserved by IEEE.	This bit will always be 0.
9	512	Reserved by IEEE.	This bit will always be 0.
8	256	Reserved by IEEE.	This bit will always be 0.
7	128	Power On	This bit is set to 1 if the power supply has been turned off and on since the last time this register was read or otherwise cleared. Defined in "IEEE Std. 488.2-1992", 11.5.1.1.2
6	64	Reserved for future use.	This bit will always be 0.
5	32	Command Error	This bit is set to 1 if the test set detects an error while trying to process a command. The following events cause a command error: <ul style="list-style-type: none"> • An IEEE 488.2 syntax error. The test set received a message that did not follow the syntax defined by the standard. • A semantic error. For example the test set received an incorrectly spelled command. • The test set received a group execution trigger (GET) inside a program message
4	16	Execution Error	This bit is set to 1 if the test set detects an error while trying to execute a command. The following events cause a execution error: <ul style="list-style-type: none"> • A <PROGRAM DATA> element received in a command is outside the legal range for the test set, or it is inconsistent with the operation of the test set. • The test set could not execute a valid command due to some test set hardware/firmware condition.
3	8	Device Dependent Error	This bit is set to 1 if a test set operation does not execute properly due to an internal condition (such as, overrange). This bit indicates that the error was not a command, query, or execution error.

Bit Number	Binary Weighting	Condition	Description
2	4	Query Error	<p>This bit is set to 1 if an error has occurred while trying to read the test set's output queue. The following events cause a query error:</p> <ul style="list-style-type: none"> • An attempt is made to read data from the output queue when no data is present or is pending. • Data in the output queue has been lost. An example of this would be an output queue overflow.
1	2	Reserved for future use.	This bit will always be 0.
0	1	Operation Complete	This bit is set to 1 when the test set has completed all pending operations and is ready to accept new commands. This bit is only generated in response to the *OPC IEEE 488.2 common command.

SYSTEM:APPLICATION

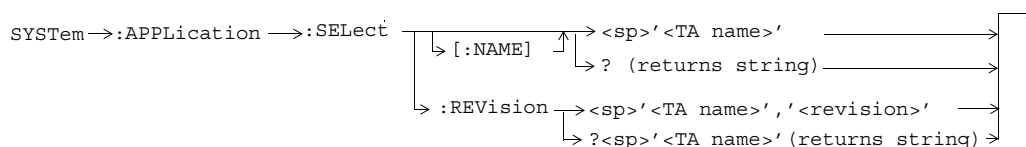
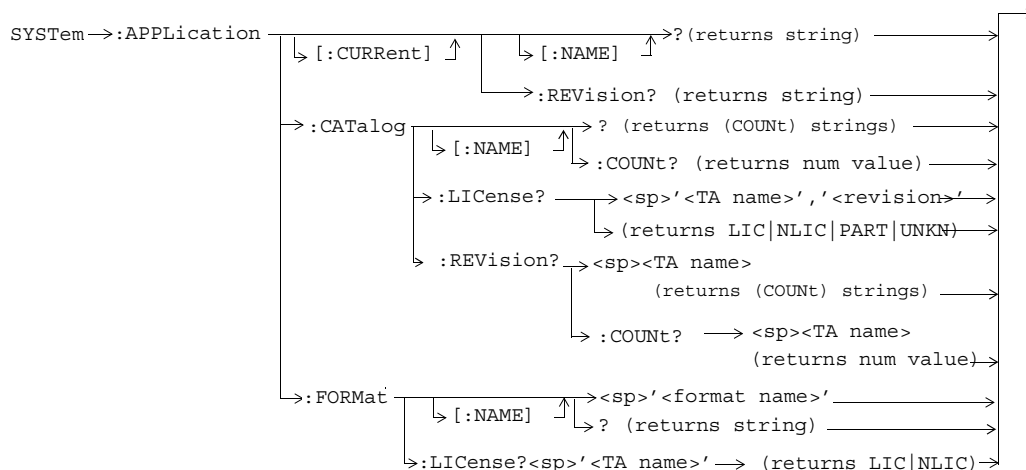

SYSTEM:BEEPER

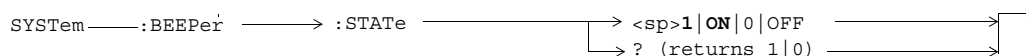

SYSTEM:CONFIGURE:INFORMATION:HARDWARE:VERBOSE?

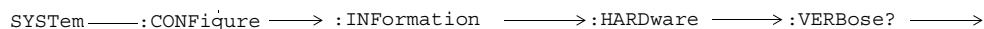

SYSTem:COMMunicate

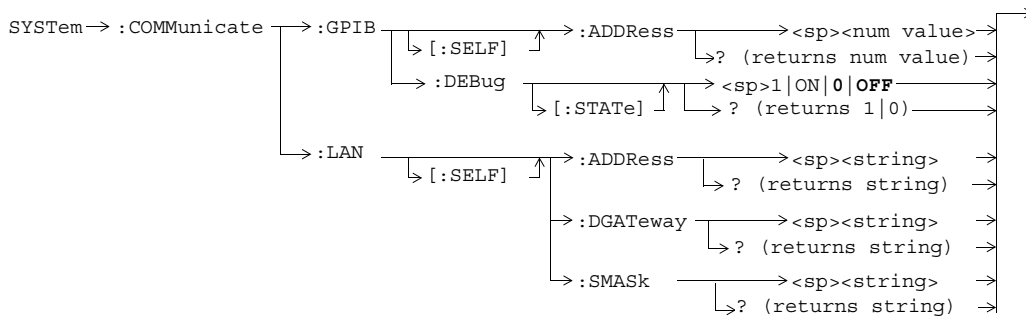

SYSTem:CORRection

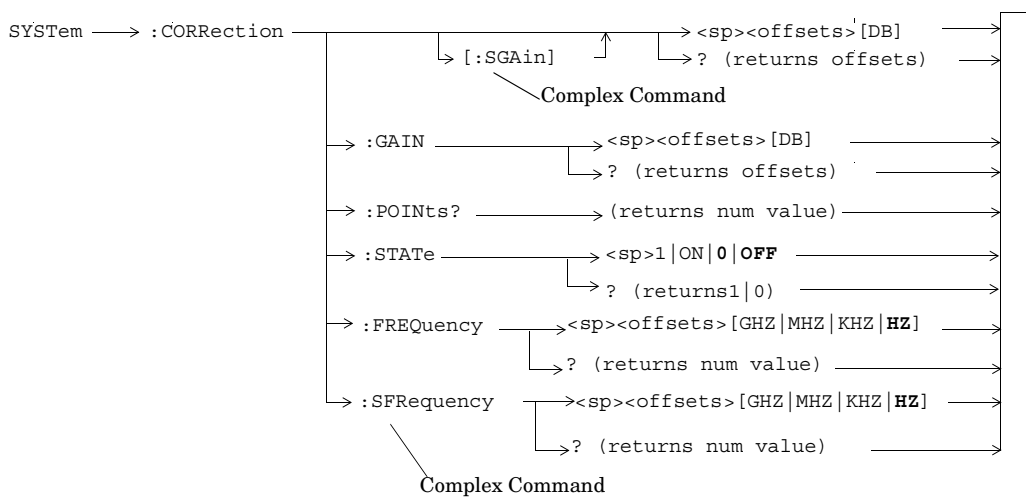

SYSTEM:CURRENT:TA

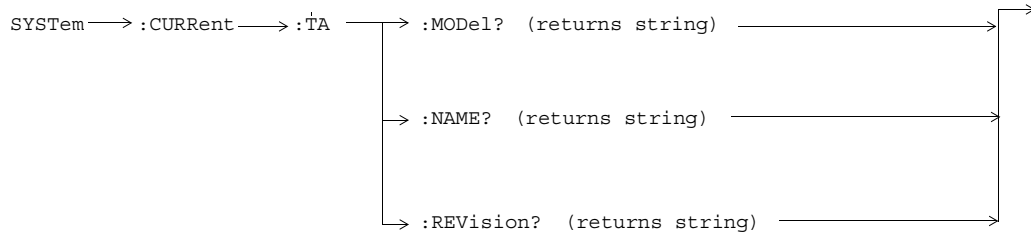

SYSTEM:ERROR?

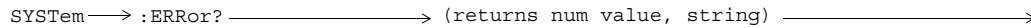

SYSTEM:MEASUREMENT:RESet

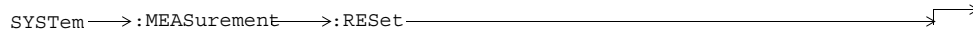

SYSTEM:PRESet

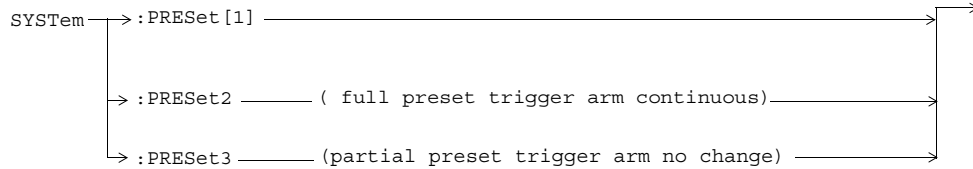

SYSTEM:ROSCillator

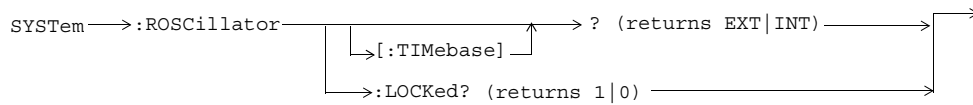

SYSTem:SYNChronized

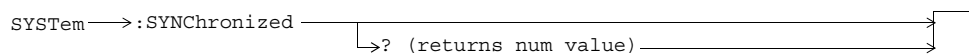

IEEE 488.2 Common Commands

Description

***CLS** The *CLS, clear status command, is defined in “IEEE Std 488.2-1992”, 10.3. This command will also clear and close the error message screen on the test set’s display.

***ESE** The *ESE, standard event status enable command, is defined in “IEEE Std 488.2-1992”, 10.10.

***ESE?** The *ESE?, standard event status enable query, is defined in “IEEE Std 488.2-1992”, 10.11.

***ESR?** The *ESR?, standard event status register query, is defined in “IEEE Std 488.2-1992”, 10.12.

*IDN?

The *IDN?, identification query is defined in “IEEE Std 488.2-1992”, 10.14. *IDN? is used to retrieve information about the test set in ASCII format.

*IDN?, returns ASCII codes 32 through 126 excluding comma and semicolon in four comma separated fields. Field 1 returns the manufacturer, field 2 returns the instrument model number, field 3 returns the serial number, field 4 returns 0.

***OPC** The *OPC, operation complete command, is defined in “IEEE 488.2-1992”, 10.18. *OPC causes the test set to continuously sense the No Operation Pending flag. When the No Operation Pending flag becomes TRUE, the OPC event bit in the standard event status register (ESR) is set to indicate that the state of all pending operations is completed. The *OPC common command is not recommended for use as an overlapped command.

***OPC?** The *OPC?, operation complete query, is defined in “IEEE Std 488.2-1992”, 10.19. The *OPC? query allows synchronization between the controller and the test set using either the message available (MAV) bit in the status byte, or a read of the output OPC?. The *OPC? query does not effect the OPC event bit in the Standard Event Status Register (ESR). The *OPC? common command is not recommended for use as an overlapped command.

*OPT?

The *OPT?, option identification query, is defined in “IEEE Std 488.2-1992”, 10.20. Each option will have a unique name, that name will be returned with the query.

***RST** The *RST, full preset command, is defined in “IEEE Std 488.2-1992”, 10.32. A full preset is also accomplished using the SYSTem:PRESet2 command. A full preset restores the majority of settings to their default values and sets measurement trigger arm to single.

***SRE** The *SRE, service request enable command, is defined in “IEEE Std 488.2-1992”, 10.34. The parameter range for this command is 0 through 255.

***SRE?** The *SRE?, service request enable query, is defined in “IEEE Std 488.2-1992”, 10.35. Values returned by this query range from 0 through 255.

***STB?** The *STB?, read status byte query, is defined in “IEEE Std 488.2-1992”, 10.36. Values returned by this query range from 0 through 255.

***WAI** The *WAI, wait-to-continue command, is defined in “IEEE Std 488.2-1992”, 10.39. The *WAI command prevents the test set from executing any further commands or queries until all pending operation flags are false. The *WAI common command is not recommended for use as an overlapped command.

Index

To find a syntax equivalent for a field on the Test Set's display.

1. Find the field name on the Test Set's display.
2. Look up the name in the alphabetical listing.
3. Turn to the page indicated.

A

access probe power
 FETCh command, 33
active cell operating mode, 20
Active Cell Status, 12
Amplitude, 9
Audio Generator, 9
AWGN Power, 11
AWGN Power (dBm/1.23 MHz)
 Current Level, 29
 Desired Level, 11

B

band class, 15
 mobile station reported, 15
base station originated call, 20
Beeper State, 65

C

Cal. first IQ mod, 10
Cal. second IQ mod, 10
call originate, 20
call processing
 active cell operating mode, 20
 carrier feedthrough
 FETCh command, 36
cdg escape mode
 , 13
Cell Band, 11
Cell MCC, 14
Cell MNC, 14
Cell Power, 22
Cell Power (dBm/1.23 MHz)
 Current Level, 28
Channel Power, 34
channel power
 initiate command, 38
 read command, 39
Code Domain Power, 37
code domain power
 read command, 39

SETup commands, 46
Code Domain Power + Noise, 37
code domain power + noise
 read command, 39
SETup commands, 46
Curr F-QPCH Level (Rel to Pilot),
 29
Curr F-QPCH State, 29

D

Data Rate, 25
DCCH frame sizes supported
 mobile station reported, 15
DCCH support
 mobile station reported, 15
debug feature, 8
Default Gateway, 66
Desired Level (dB), 19
dialed number
 mobile station reported, 18
Digital Average Power, 34
digital average power
 initiate command, 38
 read command, 39
Display Brightness, 33
Display Mode, 33

E

EIRP (effective isotropic radiated power), 15
 mobile station reported, 15
enhanced radio configuration support
 mobile station reported, 19
Escape Mode, 13
ESN
 mobile station reported, 17
ESN (Hex), 13
EVM
 FETCh command, 36
Expected CW Power, 40
External Trigger Type, 33

F

FCH Service Option Setup, 28
FCH support
 mobile station reported, 15
FER
 initiate command, 38
 read command, 39
F-FCH/Traffic
 Current Level (dB), 29
five millisecond frame support
 mobile station reported, 15
F-OCNS Walsh Code, 19

forward DCCH radio
 configurations supported
 mobile station reported, 15
forward fundamental channel
 radio configuration support
 mobile station reported, 15
F-Paging
 Current Level (dB), 29
F-Pilot
 Current Level (dB), 29
F-Pilot Level, 22
F-QPCH
 Current Level (dB), 29
F-QPCH Desired Level (dB), 23
F-QPCH Indicator Bits, 13
F-QPCH Relative Level, 23
F-QPCH State, 23
frame error rate
 initiate command, 38
 read command, 39
 SETup commands, 42
frame error rate confidence limit
 FETCh command, 34
frame error rate count
 FETCh command, 34
frame error rate frames counted
 FETCh command, 34
frame error rate integrity
 indicator
 FETCh command, 34
frame error rate measurements,
 34
 FETCh commands, 34
frame error rate ratio
 FETCh command, 34
Frequency, 9
 frequency stability, 35
Frequency (kHz)
 Minimum, Maximum, Average,
 35
Frequency (MHz)
 amplitude offset, 66
 frequency error, 35
 FETCh command, 36
frequency error (Hz)
 minimum, maximum, average,
 35
Frequency Stability
 Frequency, 35
 integrity, 35
 intermediate count, 35
frequency stability
 frequency error, 35
 initiate command, 38
 worst frequency error, 35
frequency stability setup
 measurement timeout, 45

Index

- multi-measurement count, 45
 - timeout, 45
 - trigger arm, 45
 - F-SCH
 - Current Level (dB), 29
 - F-SCH Desired Level (dB), 25
 - F-Sync
 - Current Level (dB), 29
 - F-Sync Level, 32
 - FULL (preset) key, 52
- G**
- GPIB Address, 66
- H**
- Handoff, 14
 - handoff band, setting, 26
 - handoff channel, setting, 26
 - handoff waveform quality
 - initiate command, 38
 - handoff, setting up, 26
- I**
- I, 37
 - inactive IQ channel power limit
 - code domain power, 46
 - Initial Power, 10
 - Instrument Information
 - Test Application, 67
 - integrity
 - frequency stability, 35
 - intermediate count
 - frequency stability, 35
 - IS-2000 Test, 20
- L**
- LAN IP Address, 66
 - Last Calibration, 10
- M**
- magnitude error
 - FETCh command, 36
 - Maskable Message Display State,
 - 33, 66
 - Max EIRP, 13
 - Max Request Seq, 10
 - Max Response Seq, 10
 - MCC
 - mobile station reported, 18
 - Meas Frequency, 40
 - Measurement Timeout
 - waveform quality, 46
 - measurement timeout
 - access probe power, 41
 - channel power, 43
 - digital average power, 44
 - frame error rate, 42
 - frequency stability, 45
 - Message Log, 67
 - MNC
 - mobile station reported, 18
 - MSIN
 - mobile station reported, 18
 - Multi-Measurement Count
 - waveform quality, 46
 - multi-measurement count
 - access probe power, 41
 - channel power, 43
 - digital average power, 44
 - frequency stability, 45
- N**
- Network ID (NID), 19
 - noise limit
 - code domain power plus noise, 46
 - Nominal Power, 10
 - Nominal Power Ext, 10
 - Number
 - amplitude offset, 66
 - Number of Steps, 10
 - numeric rho
 - FETCh commands, 36
- O**
- OCNS
 - Current Level (dB), 29
 - Desired Level (dB), 19
 - Offset (dB)
 - amplitude offset, 66
 - Operating Mode, 28
 - Active Cell, 20
 - IS-2000 Test, 20
 - operating mode, 15
 - mobile station reported, 15
 - originating a call, 20
- P**
- Paging Data Rate, 21
 - Paging MCC, 21
 - Paging MNC, 21
 - Paging MSIN, 21
 - Paging Type, 21
 - phase error
 - FETCh command, 36
 - phone number
 - mobile station reported, 18
 - PN Offset, 22
 - power control
 - reverse link, 12
 - reverse link step size, 12
 - power control step size
 - mobile station reported, 18
 - Power Step, 10
 - Preamble Size, 10
 - PRESET key, 52
 - programming, debug feature, 8
 - Protocol Rev, 23
 - protocol revision
 - mobile station reported, 18
 - Pulse, 9
- Q**
- Q, 37
 - queriable mobile station
 - capability
 - mobile station reported, 15
 - quick paging channel supported
 - mobile station reported, 18
- R**
- Radio Config, 23
 - Rcvr Power Ctrl, 40
 - registration period, 24
 - registration type
 - mobile station reported, 19
 - Rev, License, 65
 - reverse DCCH radio
 - configurations supported
 - mobile station reported, 15
 - reverse fundamental channel
 - radio configuration support
 - mobile station reported, 15
 - reverse power control, 12
 - RF Gen Freq, 24
 - RF Gen Freq Ctrl, 12
 - RF IN/OUT Amplitude Offset
 - State, 66
 - RF IN/OUT Amptd Offset, 66
 - RF IN/OUT Amptd Offset Setup,
 - 66
 - rho
 - FETCh command, 36
 - read command, 39
 - Rvs Link Freq, 40
 - Rvs Power Ctrl, 12
- S**
- setting up
 - access probe power, 41
 - channel power, 43
 - frame error rate, 42
 - SID, 26
 - slot cycle class
 - mobile station reported, 19
 - slot cycle index
 - mobile station reported, 19

Index

station class mark bandwidth
 support, 15
 mobile station reported, 15
step size
 reverse link power control, 12
Subnet Mask, 66
supplemental channel support
 (forward)
 mobile station reported, 16
supplemental channel support
 (reverse)
 mobile station reported, 17
system handoffs, 26
System ID (SID), 26
System Type, 32

T

Test Application
 Setup, 65
 Test Application, Revision,
 License, 65
Test Application (instrument
 information), 67
time error
 FETCh command, 36
timer based registration state, 24
Total RF Power (dBm/1.23 MHz)
 Current Level, 28
Traffic Data Rate, 32
Trigger Arm
 waveform quality, 46
trigger arm
 digital average power, 44
 frequency stability, 45

W

waveform quality
 initiate command, 38
 read command, 39
waveform quality/code domain
 FETCh commands, 36
waveform quality/code domain
 power
 read command, 39
 SETup commands, 46
worst frequency error, 35